

My Search for the Ultimate VHF/UHF Station

Al Duncan – VE3RRD (ve3rrd@rac.ca)

Updated 14 December 2006

On thinking over what type of VHF/UHF station I would want to set up for mobile/home use, the following considerations were explored.

1. The cost of having multiple high quality transceivers in my car, and house, and for transportable/emergency use.
2. Weight and size of an AC power supply.
3. The ease of disconnecting/reconnecting power from different sources and at different locations.
4. Emergency power from a battery or generator.
5. The desire to have something transportable that could be set up anywhere (such as for ARES, communications support for local events, Field Day etc.
6. Mobile, base station and portable antenna systems for 2M and 440 that weren't overly expensive.
7. How to get around the high levels of intermod and other interference that would be experienced.

Cost:

Since like most of us, I don't have unlimited funds to spend on new ham equipment (the last mobile rig I bought was an ICOM IC-28H purchased new in 1985), I wanted something reliable that could be used for any application. Since most of my existing equipment is ICOM, I looked around for what this manufacturer had to offer. I didn't necessarily want the newest rig (not enough time for users to find all the bad points about it), but wanted something modern with a detachable control head.

The ICOM [IC-208H](#) dual band mobile rig seemed to fit my requirements (although it is several years old now – first introduced in 2003) and happened to be on sale at [Radio World](#) in Toronto (this transceiver has been on sale for as low as \$329).



Other manufacturers also have excellent choices in 146/440 MHz rigs, just remember to check for user comments on a site such as eHam.net before committing to buy.

AC Power Supply:

An old style transformer (linear) power supply may be an excellent choice for a fixed application, but for something compact and lightweight, a switching type is the way to go. Several good switching P/S have been introduced recently, most notably:

The [Alinco DM-330MV](#) compact switching power supply rated at 30A continuous output ([eHam review](#)), which is often put on sale by Ham Radio stores such as [Radio World](#) and [Durham Radio](#). Another good choice is the [Samlex SEC1223](#) rated at 23A continuous output.



The Samlex unit ([eHam review](#)), which can be found on some US ham equipment discount websites (such as [Universal Radio Inc.](#)) for as little as US \$90 (you will find it for about \$179 at dealers in Ontario). With dimensions of 2.4 x 7.3 x 8.7 inches and a weight of 3.5 pounds, it is a good choice for a “portable” high current power supply. This unit can be further

improved by performing the [ZL2DF mod](#) which adds additional filtering to the DC output lines (eliminates birdies noted on 40, 80 and 160M HF).

Don't skimp on the power supply capacity, you may think you will never need 23A but this power supply could be used to power a 100W HF transceiver, and the cost of up-sizing on your initial purchase isn't that great.

Check out DL2YEO's design [here](#) and [here](#) to build your own switching power supply. An even simpler design can be found [here](#).

DC power connection:

The “official” [power connector](#) for [ARES and other](#) group compatibility is the [Anderson Powerpole](#), available in 15A (PP15 – 1395/1395G1) and 30A (PP30 – 1330/1330G4) versions. You can get a [package of 20](#), (10 black and 10 red housings, with 10 – 15A and 10 – 30A contacts) for \$10.95 from [Durham Radio](#). Another source is [MCM](#) in the U.S. who sells packages of 20 of the 30A style (10 red, 10 black + 20 contacts) for US \$10.76.

Housings should be mated according to the diagram to right, viewing from the contact side (opposite the wire side), tongue down, hood up, RED on the LEFT, BLACK on the RIGHT. Also notice the 3/32-inch-diameter roll pin, 1/4 inch long, is used to keep the housings from sliding apart. Better quality crimping tools such as the [PWRcrimp](#) are available.

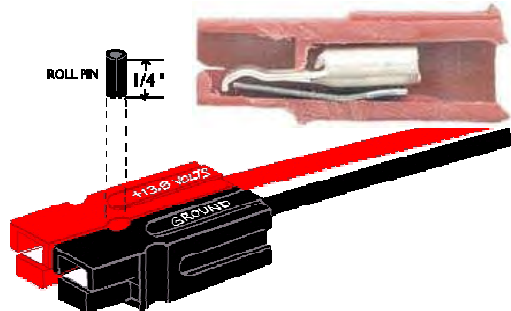

The big advantage with the Anderson PowerPole connector, is that it is the contact piece that determines the current handling rating – the plastic body is the same for the 15A, 30A and 45A versions. This means, for example, that a 15A transceiver connector can be plugged into a 30A power supply connector. The different current versions are rated for different sizes of wire: #16 to #20 AWG for the 15A, #12 to #16 AWG for the 30A (although 10 gauge can be squeezed in), and #10 to #14 AWG for the 45A contact. The same plastic body is used for the source and the load side connector. The connector is also “genderless” – when [assembled as shown](#) above (both source and load side), any two connectors can be plugged together, the polarity of the voltage will be correct since one connector must be turned over to plug into the other.

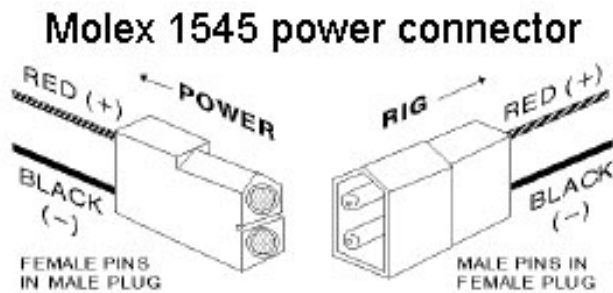

Special tool needed to remove pins

tubing slides onto the front of the female/male pin (must have thin enough wall to fit inside the hole in the connector body) and compresses the locking tabs so that the pin and wire can be pulled out the rear of the connector.

Another older power connector standard sometimes used (for lower current applications) is the Molex 1545. These are not as easy to assemble and require soldering the male and female pins to the wire before snapping them into the nylon connector bodies. A special tool is required to extract the pins (if you put them in the wrong hole), although a substitute tool can be fashioned from thin-wall brass tubing from a hobby shop. The

The cheap-and-simple non-standard connector:



cables in both of my vehicles and in my work van. Once I get some of the 30A Powerpole connectors, I will convert everything over.

For lower current applications (15A or less), I have been using 4 pin, flat style trailer connectors. By doubling up the contacts (2 for hot, 2 for ground) they seem to work quite well and can be found in many stores (about \$4 for both halves). I have these installed on both the IC-28H and IC-208H power cords, and the mating ends on my AC power supply in the house and on the power

Emergency power:

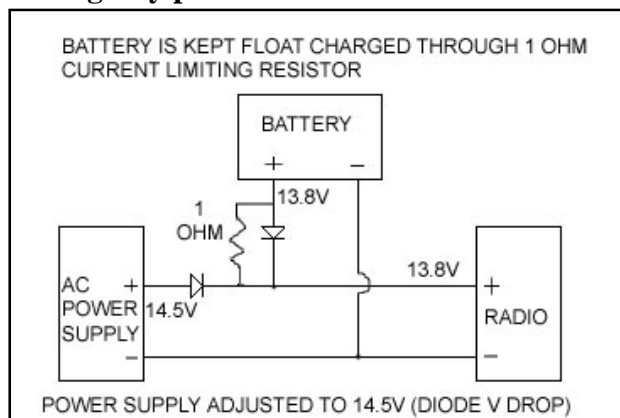

The most common method of powering a mobile rig during a power outage (outside of using it in a vehicle), is from a battery such as a marine deep-cycle type. The ICOM IC-208H draws up to 12A on high power, so a reasonably hefty battery would be required to power it for any length of time. The battery must be kept charged, either by the use of an automatic battery charger, or by float-charging it across the transceiver’s AC power supply.

Float charging requires adding two rectifier diodes rated for the load current, and a battery charge current limiting resistor of 1 ohm. Note that the power supply must have the voltage adjusted higher by .7V (the drop across the diode) so that 13.8V will reach the battery (to charge it) and the radio. When the AC power fails, the battery will begin sourcing current to the radio through its diode. The only other issue is that the diode will reduce the battery voltage to the radio (by .7V), a 115VAC powered relay could be connected to bypass this diode when the AC fails. If the battery is a heavy duty deep-cycle type for example - after being partially or fully discharged, it should be recharged with an automatic battery charger before reconnecting it to the power supply for float charging. Just remember that you cannot connect your transceiver to the battery while it is being charged.

Note that the Schottky diode has about half the voltage drop that a regular rectifier diode has.

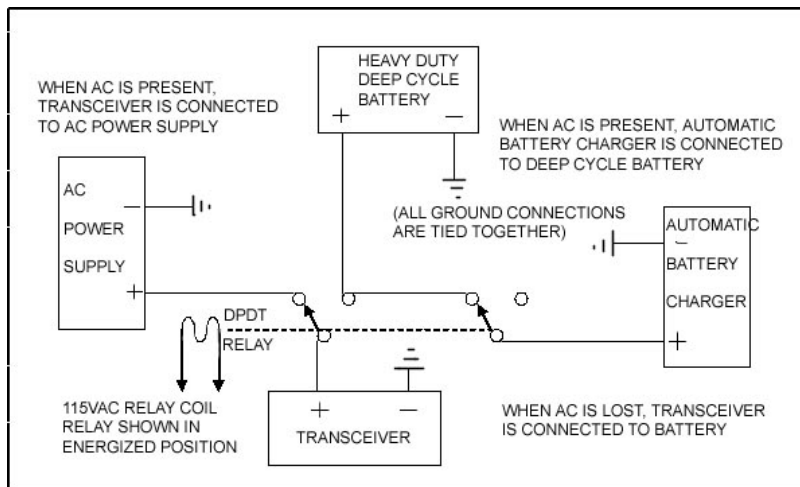

The automatic battery charger is a simpler solution, but power will not be available during the time it takes to connect the battery to the transceiver. A 115VAC relay could be used to connect the battery to the automatic charger and connect the transceiver to the AC power supply. Upon the loss of AC to the relay, it would be de-energized, connecting the battery to the transceiver (both the battery charger and the AC

power supply would be disconnected). The relay contacts should be rated for 20A or more. Note that power to the transceiver will be lost for an instant as the relay switches, a 3000 or 4000 microfarad capacitor across the transceiver input could smooth this out.

The next problem is that most transceivers don't like it when the DC voltage drops to 11V or so during transmit, which will occur when using a deep-cycle battery (part of the discharge curve is below 11VDC). It will also occur if there are any voltage drops because of wire resistance or if any diodes are placed in series with the power supply output causing additional voltage loss below 13.8V. Use 10 gauge stranded for both +12V and the ground wire to reduce the voltage drop.

A device that fixes the low voltage problem is the "[Electronic Battery Booster](#)" from W4RRY (reviewed in [October 2005 issue of QST](#)). It is available for US\$120.



Table 3
W4RRY Battery Booster Efficiency

Input V	Input A*	Input W	Output V	Output A*	Output W	Efficiency %
10.3	24	247	13.7	16	219	89
12	22	264	13.8	16	220	84
13.3	20	266	13.8	16	220	83
10.4	11	114	13.8	8	110	97
12.1	8	97	13.8	6	83	86

*The current results, and derived data, are approximate since the available probe had a resolution of 1 A.



Another similar device is the [N8XJK 12V Boost Regulator](#) which can be [purchased in kit form](#) for US\$99.95 or assembled for US\$130. It is capable of operating over a wide input range of 9V to 15V.

A method sometimes used to prevent the battery voltage from dropping below the minimum required by equipment is to use a “seven cell” battery. The nominal terminal voltage of a six cell battery is approximately 12.6V; the nominal voltage of a seven cell battery is 14.7V. The float charge voltage of a 6 cell is 13.8V while that of a 7 cell is about 16.1V. The advantage is that the discharged terminal voltage of a deep cycle 6 cell battery is about 11V, while that of the 7 cell is about 12.8, an acceptable voltage for a transceiver. There is one problem though – amateur equipment (and other 12V electronic equipment) is not made for operation above about 15V. To prevent this during battery charging and while operating on the float power supply, several diodes in series must be switched in to reduce the voltage to the radio. Three diodes would be enough to reduce the 16.1V float voltage to 14V for the transceiver. A relay controlled by a voltage sensing circuit would be required to bypass the diodes as the battery terminal voltage drops below 14V, and to switch the diodes back in when AC is restored and the 16.1V power supply drives the battery terminal voltage above 14V. Often though, after the battery has been partially or moderately discharged, the automatic battery charger will apply a voltage higher than 16.1V to obtain the required charge current.

Another possibility is to use a [portable generator](#) – either a 115VAC version or a 12VDC generator ([check here](#) for one made from a lawn mower engine and car alternator, another version can be found [here](#)). Many gasoline engines can be [converted to propane](#). The battery would only be needed to power the transceiver until the generator could be brought on-line. A design for a trickle charger for an automobile or deep-cycle battery can be found [here](#).



A short duration solution (for lower TX output power) is a portable car “jump start” unit such as the one I purchased from Princess Auto for \$38 (picture to left). It includes a 15 Ahr sealed lead acid battery and a charger. The IC-208H draws about 4A on low (5W) power, about 6A on medium (15W) power and about 11-12A on high (55W) power.

Small gel cells (for example 7 Ahr), such as those described in “[Care and Feeding of Gel Cell Batteries](#)”, are more suited for emergency handheld transceiver operation. Also refer to the eHam.net article on [recharging handheld radio batteries](#).

The simplest solution for emergency power would be for me to use a large deep-cycle automotive battery and either the W4RRY or N8XJK electronic battery booster to power my IC-208H.

DC power wire size:

Don't skimp on the gauge (size) of wire used to connect the transceiver to the power supply. This is especially important when using a battery for emergency backup – you want as little voltage drop in the DC power wiring as possible. 12 AWG, or better yet, 10 AWG should be used to connect to the transceiver.

The [American Wire Gauge Standard](#) specifies that 12 gauge is suitable for 9.3A and 10 gauge is suitable for 15A, when using longer runs of cable. The calculator on their web page indicates that 10 feet of 12 gauge wire with 12 Amps load will have a 0.5V drop. If using 10 gauge, the drop will be 0.3V.

Transportable station:

With a modern transceiver having a removable faceplate, like the IC-208H, the 3 parts of the radio that you must find room for in your mobile installation is the control head, the microphone and a small speaker. These can be temporarily attached with Velcro so that they can easily be moved with the radio. The radio itself can be located anywhere, and only needs 12VDC and an antenna connected in addition to the 3 parts mentioned. This leads to the question, “why mount the radio at all?” – why not put the radio and even the 12V power supply (such as the Samlex SEC1223) into a [box](#) with a handle. Installing the transceiver into a different location such as one of my other vehicles or my house then only involves:

- Attaching the control head, speaker and microphone to the locations already prepared for them.
- Plugging the radio power cord either into the AC supply if located where there is AC available, or into the DC power cable already installed in the vehicle.
- Attaching the antenna coax, or mounting a mag-mount antenna if the antenna is not permanent

As a temporary or emergency setup, the control head, speaker and microphone would be mounted on the box so that the entire station could be set on a table and used. A list of Ham Radio emergency items can be found [here](#).

Affordable antennas:

Several antenna configurations should be considered:

- A permanent base-station antenna for use at home.
- One or more permanent mobile antenna installations in the most used vehicles.
- A magnet-mount antenna installation for more temporary mobile use.
- A portable antenna system that can be deployed for emergency use.

After looking around for a suitable dual band mobile antenna, I came across the TRAM model 1180 which can be purchased from [Maple Leaf Communications](#) (Bob VE3BFM) in Everett for \$39.95. He also sells suitable NMO hole-mount and mag-mount hardware for it. eHam reviews were very favorable regarding both the [1180 mobile antenna](#) and also the dual band TRAM model [1480 base station antenna](#) which Bob also sells (\$99.95).

For emergency use, a magnet mount mobile antenna can be placed on a metal ground plane (even several metal coat hangers will work), see my article “[Cheap and Ugly Dual Band Whip](#)” for how to convert an old cellular mag-mount antenna to a 146/440 antenna; or a two element quad (like that shown in “[RDF and Hidden Transmitter Hunting](#)”) or [J-Pole](#) could be used ([another J-pole](#)). Quality ready made portable J-pole antennas are available from [Maple Leaf Communications](#). You can make a good quality, high gain 2 meter yagi from an [old TV](#) or [FM antenna](#). Even the [Tape Measure Yagi](#) could be used in a pinch.

A folding portable 2M antenna could be made from four or six 21 inch or longer telescoping antennas for the ground plane radials attached to a brass washer (hole in center can be used for the antenna mount). A telescoping 5/8 wave antenna (made for a handheld) could be used with a BNC feed through for lower power applications.



Choice of coax connector:

In most cases, the PL-259 UHF connector will work well for fixed and mobile transceivers, and may be your only choice when using larger coax such as RG-8 or RG-213. When using RG-58 style coax, another choice is the BNC connector. The BNC connector can be attached directly to many handheld transceivers, or adapters can be used to interface to the SO-239/UHF, type N, or smaller connectors such as the SMA, TNC or mini-UHF often used on modern handhelds. An emergency antenna with a BNC connector, and a half dozen adapters will allow you to attach your antenna to most amateur equipment that may be available for use.

Likewise, a number of adapters to allow available antennas to be attached to your transceiver can be very useful. The most common being adapters to convert BNC and type N coax connectors to the UHF/SO-239 used on the average mobile ham radio transceiver.



Although my Icom IC-208H uses a UHF style connector, my handheld (a Yaesu FT-50RD) uses an SMA connector (my old Icom IC-02AT uses a BNC connector). Hanging a PL-259 off of a UHF to SMA adapter (if such a thing were available) would be asking for damage to the FT-50. In my case, if I plan on using my handheld with my mobile antenna, it would be better to put a BNC connector on the coax and use the appropriate adapter to interface to the IC-208H or FT-50RD. Another option is to make up a short piece of RG-58 with a SMA male on one end and a SO-239 on the other. A good selection of [RF connectors](#) and [RF adapters](#) are available from [Durham Radio](#).

Choice of coax cable:

The choice of what coax to use is a trade-off between diameter/weight/flexibility and signal loss for the frequency used. A 3db loss is the same as cutting your transmitter output power in half.

- For very short lengths, very small diameter coax such as RG-174 can be used. At 146 MHz, 10 feet of RG-174 loses about 1.3 db, and at 440 MHz, 10 feet loses about 2.5 db., costs about 35 cents/foot.
- For less loss/longer lengths, RG-58 coax can be used. The 146/440 MHz losses for 10 feet of RG-58A/U is about 0.61db/1.04 db. Note that RG-58 comes in two versions; standard dielectric RG-58C/U at about 25 to 30 cents/foot, and the better quality lower loss foam dielectric type RG-58A/U (you can find this at the same price as the C/U).
- The next step up is RG-8X coax with 146/440MHz losses of 0.45db/0.81db for 10 ft. and costs about 80 cents/foot.
- Larger RG-8/RG-213 coax has 146/440 MHz losses of 0.28db/0.51db for 10 ft. and costs about 75 to 80 cents/foot.
- A new product called LMR-400 which is about the diameter of RG-8 but is much less flexible (100% shielded) and has lower loss can be found for about \$1.50/ft. You may find lengths of this for less at a HamFest or on eBay. It is made for permanent installations, with losses for 10 feet of about 0.15db/0.27db at 146/440 MHz.

Only buy black outdoor (UV rated) coax, stay away from other colors such as grey (often seen for RG-8X) unless you plan to only use it indoors – sunlight will make the outer covering turn hard and brittle.

Bulk quantities of coax cable such as RG-58 and RG-8 can be purchased from [Maple Leaf Communications](#) and from [Durham Radio](#).

PL-259 UHF connectors can be attached to LMR-400 coax using the following guideline:

Make sure to clean/sand the surface near the holes and the inner edges of the holes before soldering. Do that either with an X-acto knife or a thin bamboo skewer with a small piece of #200 sandpaper wrapped around the end. I usually stick some resin into each hole that I'm about to solder, to help the solder flow. Use at least a 100 W iron. Let enough solder go through the hole onto the shield and heat it until it really flows well, but do not overheat the cable! Learning when to stop is the whole secret to making good connectors. After removing the iron make sure you wait a longish time (30 sec or so) for the solder to cool down before you move anything.

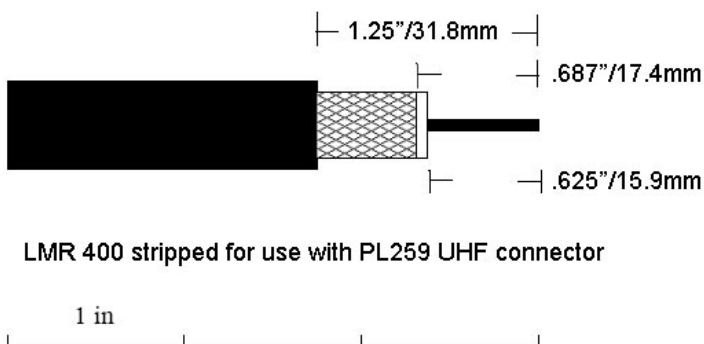

Interference protection:

The broad-banded receivers used in most new transceivers are susceptible to interference from various paging/trunking and other commercial transmitters located everywhere today. Every city has its “intermod alley”; in the city of Barrie it is Bayfield St. near the Kozlov mall, and near the CKVR television tower to name two. My new IC-208H also experiences problems in these areas, although my old IC-28H (2M only rig) included a helical filter in the receiver, which kept most of this out.

When providing emergency communications, the last thing you want is to not be able to hear the repeater or other emergency stations because of [intermod](#) clobbering your receiver. A quick method to check if the [interference](#) you have can be helped by adding a filter; is to add a 10dB attenuator in front of the transceiver. If the interference is gone or greatly reduced, then a band-pass filter will help. In this case (the most common) the intermodulation products you are hearing are actually caused by strong signals which can be outside the amateur radio band (for example paging transmitters located just below and above the 2M band). These signals enter through your antenna and mix together inside your receiver to create the interference called “intermod”.

A type of interference that cannot be helped by a filter on your transceiver is when the mixing occurs outside your radio, possibly even on a paging transmitter tower. If the interference resulting from this mixing falls within the ham bands you are listening to, then the radio will receive it the same as any amateur repeater signal.



An excellent dual band filter covering 144-148MHz and 438-450MHz (model [DCI-146-444-DB](#)) is made by [DCI Digital Communications Inc.](#) With a size of 4” x 4” x 8” and a weight of 3.5 pounds, it is small enough to add to my “box” containing the transceiver and power supply. The unit can be [ordered](#) directly from their factory in Saskatchewan for \$220.

Unsolicited testimonials from owners can be seen both on [their website](#) and on [eHam](#).

Another type of interference that can cause a problem, especially if the antenna is too close to the transceiver, is RF feedback. In this case the transceiver’s own RF from the antenna gets back into the transceiver either directly through the radio enclosure or by riding in on the microphone or external speaker cables or even the DC power cables. Moving the antenna can help solve this problem, and installing snap-on RF choke type filters on all cabling entering or leaving the transceiver enclosure can also help. The type shown to the right consists of a powdered ferrite material and is sized to fit RG-58 or similar diameter cables. Some additional info about preventing RFI (radio frequency interference) can be found [here](#) and also [here](#).

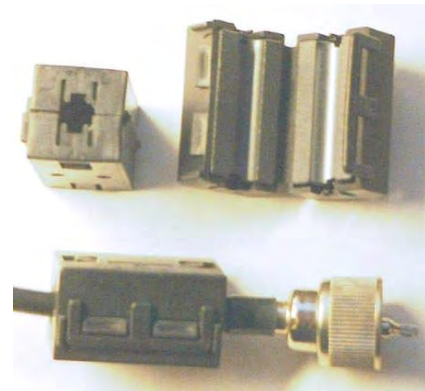

Check “[Where to Shop for Electronic and Amateur Radio Parts and Equipment](#)” for stores that sell these.

An excellent source of information is the [KOBG website](#) for mobile Amateur Radio operators.

Internet Links Found in This Document

Page 1

The ICOM [IC-208H](http://www.icomamerica.com/products/amateur/208h/) - <http://www.icomamerica.com/products/amateur/208h/>
at [Radio World](http://www.radioworld.ca/) in Toronto - <http://www.radioworld.ca/>
such as [eHam.net](http://www.eham.net/reviews/detail/3218) - <http://www.eham.net/reviews/detail/3218>

Page 2

The [Alinco DM-330MV](http://www.alinco.com/Products/DM330MVE/) - <http://www.alinco.com/Products/DM330MVE/>
([eHam review](http://www.eham.net/reviews/detail/765)) - <http://www.eham.net/reviews/detail/765>
Such as [Radio World](http://www.radioworld.ca/) - <http://www.radioworld.ca/>
and [Durham Radio](http://www.durhamradio.com/s/home.php) - <http://www.durhamradio.com/s/home.php>
the [Samlex SEC1223](http://www.samlexamerica.com/products/productdescription.asp?ProductsID=3602) - <http://www.samlexamerica.com/products/productdescription.asp?ProductsID=3602>
Samlex unit ([eHam review](http://www.eham.net/reviews/detail/432)) - <http://www.eham.net/reviews/detail/432>
[Universal Radio Inc.](http://www.universal-radio.com/catalog/hamps/3747.html) - <http://www.universal-radio.com/catalog/hamps/3747.html>
[ZL2DF mod](http://www.n0ss.net/samlex_1223_rfi_mods_from_zl2df.pdf) - http://www.n0ss.net/samlex_1223_rfi_mods_from_zl2df.pdf
DL2YEO's design [here](http://www.qrp4u.de/docs/en/powersupply/) - <http://www.qrp4u.de/docs/en/powersupply/>
and [here](http://www.qrp4u.de/docs/en/smpps_new/) - http://www.qrp4u.de/docs/en/smpps_new/
simpler design can be found [here](http://www.angelfire.com/planet/als_space/ham/simple_switcher.pdf) - http://www.angelfire.com/planet/als_space/ham/simple_switcher.pdf
"official" [power connector](http://www.ocraces.org/powerpole.html) - <http://www.ocraces.org/powerpole.html>
[ARES and other](http://www.thegallos.com/ppole.htm) - <http://www.thegallos.com/ppole.htm>
[Anderson Powerpole](http://home.comcast.net/~buck0/app.htm) - <http://home.comcast.net/~buck0/app.htm>
[package of 20](http://www.durhamradio.com/s/product.php?productid=45291&cat=1766&page=1) - <http://www.durhamradio.com/s/product.php?productid=45291&cat=1766&page=1>
[Durham Radio](http://www.durhamradio.com/s/home.php?cat=1766) - <http://www.durhamradio.com/s/home.php?cat=1766>
[MCM](http://site.mcminone.com/product.asp?catalog_name=MCMPProducts&product_id=21-3300) - http://site.mcminone.com/product.asp?catalog_name=MCMPProducts&product_id=21-3300
[PWRcrimp](http://www.westmountainradio.com/PWRcrimp.htm) - <http://www.westmountainradio.com/PWRcrimp.htm>

Page 3

[assembled as shown](http://www.flyrc.com/articles/using_powerpole_1.shtml) - http://www.flyrc.com/articles/using_powerpole_1.shtml

Page 4

[Electronic Battery Booster](http://www.members.cox.net/w4rry/index.html) - <http://www.members.cox.net/w4rry/index.html>
[October 2005 issue of QST](http://www.flex-radio.com/articles_files/2005-10_QST_Review.pdf) - http://www.flex-radio.com/articles_files/2005-10_QST_Review.pdf

Page 5

[N8XJK 12V Boost Regulator](http://stores.tgelectronics.org/default.htm) - <http://stores.tgelectronics.org/default.htm>
[purchased in kit form](http://stores.tgelectronics.org/cataloglist.html) - <http://stores.tgelectronics.org/cataloglist.html>
[portable generator](http://www.angelfire.com/planet/als_space/ham/Generators.pdf) - http://www.angelfire.com/planet/als_space/ham/Generators.pdf
12VDC generator ([check here](http://www.angelfire.com/planet/als_space/ham/12V_generator.pdf) - http://www.angelfire.com/planet/als_space/ham/12V_generator.pdf
another version can be found [here](http://theepicenter.com/tow082099.html) - <http://theepicenter.com/tow082099.html>
[converted to propane](http://www.propane-generators.com/) - <http://www.propane-generators.com/>
trickle charger ... [here](http://www.angelfire.com/planet/als_space/ham/Trickle_charger.pdf) - http://www.angelfire.com/planet/als_space/ham/Trickle_charger.pdf
[Care and Feeding of Gel Cell Batteries](http://www3.sympatico.ca/alduncan/ham/Gel_Cell_Batteries.pdf) - http://www3.sympatico.ca/alduncan/ham/Gel_Cell_Batteries.pdf
[recharging handheld radio batteries](http://www.eham.net/articles/12354) - <http://www.eham.net/articles/12354>

Page 6

[American Wire Gauge Standard](http://www.powerstream.com/Wire_Size.htm) - http://www.powerstream.com/Wire_Size.htm
a [box](http://home.comcast.net/~buck0/combox.htm) with a handle - <http://home.comcast.net/~buck0/combox.htm>
emergency items can be found [here](http://www.tcoek12.org/~tcarc/hlist.html) - <http://www.tcoek12.org/~tcarc/hlist.html>
[Maple Leaf Communications](http://www.mapleleafcom.com/) - <http://www.mapleleafcom.com/>
1180 mobile antenna - <http://www.eham.net/reviews/detail/1920>
1480 base station antenna - <http://www.eham.net/reviews/detail/2276>
[Cheap and Ugly Dual Band Whip](http://www.angelfire.com/planet/als_space/ham/Cheap_and_Ugly_Whip.pdf) - http://www.angelfire.com/planet/als_space/ham/Cheap_and_Ugly_Whip.pdf
[RDF and Hidden Transmitter Hunting](http://www3.sympatico.ca/alduncan/ham/RDFing.pdf) - <http://www3.sympatico.ca/alduncan/ham/RDFing.pdf>
[J-Pole](http://www.angelfire.com/planet/als_space/ham/PVC_Jpole.pdf) - http://www.angelfire.com/planet/als_space/ham/PVC_Jpole.pdf
another J-pole - <http://www.arrl.org/tis/info/pdf/0302038.pdf>

J-pole ... from [Maple Leaf Communications](http://www.mapleleafcom.com/jpole.htm) - <http://www.mapleleafcom.com/jpole.htm>
yagi from an [old TV](http://www.angelfire.com/planet/als_space/ham/TV_to_2M_yagi.pdf) - http://www.angelfire.com/planet/als_space/ham/TV_to_2M_yagi.pdf
or [FM antenna](http://www.angelfire.com/planet/als_space/ham/5_element_2M_yagi.pdf) - http://www.angelfire.com/planet/als_space/ham/5_element_2M_yagi.pdf
[Tape Measure Yagi](http://home.att.net/~jleggio/projects/rdf/tape_bm.htm) - http://home.att.net/~jleggio/projects/rdf/tape_bm.htm

Page 7

[RF connectors](http://www.durhamradio.com/s/home.php?cat=1761) - <http://www.durhamradio.com/s/home.php?cat=1761>

[RF adapters](http://www.durhamradio.com/s/home.php?cat=1760) - <http://www.durhamradio.com/s/home.php?cat=1760>

[Durham Radio](http://www.durhamradio.com/s/home.php) - <http://www.durhamradio.com/s/home.php>

Page 8

RG-58 and RG-8 ... [Maple Leaf Communications](http://www.mapleleafcom.com/wire1.htm) - <http://www.mapleleafcom.com/wire1.htm>

from [Durham Radio](http://www.durhamradio.com/s/home.php?cat=1705) - <http://www.durhamradio.com/s/home.php?cat=1705>

Page 9

[intermod](http://www.angelfire.com/planet/als_space/ham/Intermod.pdf) - http://www.angelfire.com/planet/als_space/ham/Intermod.pdf

[interference](http://www.rsgb.org.uk/emc/emcwebsite/leaflets/emc4interferencetoamateurreceptionmembers.pdf) - <http://www.rsgb.org.uk/emc/emcwebsite/leaflets/emc4interferencetoamateurreceptionmembers.pdf>

model [DCI-146-444-DB](http://www.dci.ca/pdf/DCI-146-444-DB.pdf) - <http://www.dci.ca/pdf/DCI-146-444-DB.pdf>

[DCI Digital Communications Inc](http://www.dci.ca/?Section=Products&SubSection=Amateur) - <http://www.dci.ca/?Section=Products&SubSection=Amateur>

[ordered](http://www.dci.ca/?Section=Ordering) directly from their factory - <http://www.dci.ca/?Section=Ordering>

testimonials ... on [their website](http://www.dci.ca/?Section=Amateur-Reviews) - <http://www.dci.ca/?Section=Amateur-Reviews>

and on [eHam](http://www.eham.net/reviews/detail/271) - <http://www.eham.net/reviews/detail/271>

preventing RFI ... [here](http://www.hamuniverse.com/rfi.html) - <http://www.hamuniverse.com/rfi.html>

and also [here](http://www.qsl.net/n1lo/rfi.htm) - <http://www.qsl.net/n1lo/rfi.htm>

Where to Shop ... Parts and Equipment - http://www3.sympatico.ca/alduncan/ham/parts_stores.htm

[K0BG website](http://www.k0bg.com/index.html) for mobile Amateur Radio operators - <http://www.k0bg.com/index.html>