

Earth Grounding and Bonding Pamphlet

A Guide to Proper Earth Grounding and Bonding
Methods for Use with Tactical Systems

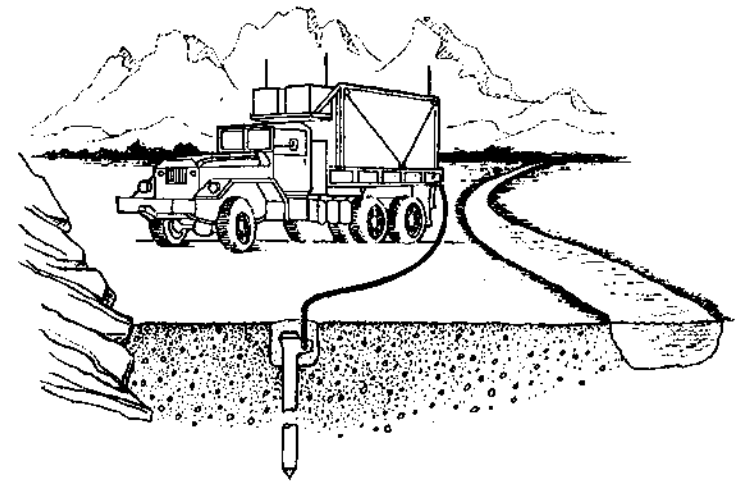

Andrew Burbelo, CSP
John M. Tobias, PE
CECOM DSRM

October 1998

DISTRIBUTION STATEMENT
Approved for public release;
distribution is unlimited.

U.S. Army Communications-Electronics Command (CECOM)
CECOM Directorate of Safety Risk Management (DSRM)
ATTN: AMSEL-SF-SEP
Fort Monmouth, New Jersey 07703-5024

NOTICES

Disclaimers

The findings in this report are not to be construed as an official Department of the Army position, unless so designated by other authorized documents.

The citation of trade names and names of manufacturers in this report is not to be construed as official Government endorsement or approval of commercial products or services referenced herein.

Note: This technical report supersedes TR 96-2, dated May 1996

1. The Earth Grounding System	1
2. Earth Grounding System Key Components	2
3. Selection of an Earth Grounding Electrode	8
4. Ground Rod Installation	9
5. Surface Wire Ground Kit (SWGK) Installation	10
6. Ground Plate Installation	11
7. Grounding to Underground Objects	12
8. Installing Horizontal Conductors and Rods	12
9. Improving Soil Conductivity	13
10. Tips for Grounding in Poor Soil Conditions and Environments	14
11. Bonding of Collocated Equipment, Shelters, and Generators	17
12. How Good is a Good Earth Ground Reference	19
13. Lightning Protection	20
14. Lightning Protection Systems: Considerations, Examples and Applications	23
15. Bonding for Lightning Protection	29
Appendixes:	
A. Grounding Systems and the Confusion about Grounding	30
B. Additional Documentation and References	33
C. The Threat	34
D. Hazards Due to Step Potentials	35
E. Earth Grounding Test	37
F. Personnel Protection from Lightning	40
G. Energized Equipment Surfaces Checks and Precautions	41
H. Definitions	44
I. Grounding Checklist	45

NEED MORE INFORMATION?

In addition to the information in this pamphlet, more information is available in the documents listed in Appendix B. In particular, see:

- FM 11-487-4
- MIL-HDBK-419A
- NFPA 70 (National Electrical Code)
- NFPA 780 (Lightning Protection Code)

For help, contact:

- Your local Safety Office
- Your CECOM Logistics Assistance Representative
- The CECOM Directorate of Safety Risk Management

You can call CECOM DSRM at DSN 992-9SAF or (732) 532-9SAF, or write to:

Commander
CECOM DSRM
ATTN: AMSEL-SF-SEP
Fort Monmouth, NJ 07703-5024

email: amsel-sf@CECOM3.monmouth.army.mil

SAFE EARTH GROUNDING AND BONDING OF COMMUNICATIONS-ELECTRONICS EQUIPMENT IN THE FIELD

This pamphlet describes different earth grounding systems and provides guidance on the proper methods for their installation, as well as proper bonding. Earth grounding helps to protect personnel and equipment from electrical faults, power surges, and other surges and transients. Earth grounding also helps reduce circuit noise and other transmission interference that can degrade Communications-Electronics (C-E) system performance. Proper bonding helps to ensure that personnel are not exposed to voltage potentials between two metal enclosures, such as collocated shelters. Often, little training or information is provided in technical manuals to address the proper methods of earth grounding system installation. These instructions will help you to set up an effective and safe earth grounding system for your equipment or shelter.

1. THE EARTH GROUNDING SYSTEM

An earth grounding system (figure 1) helps keep the electrical potential on noncurrent-carrying metal surfaces at a similar level as that of the surrounding earth. Earth grounding also provides a preferred discharge path for externally generated electrical surges due to power switching, faults, lightning, etc. This earth ground reference is established by firmly connecting a suitably sized wire to the equipment (generator, C-E system, shelter, etc.) and running it to a buried metal electrode (ground rod, water pipe, plates, etc.) which is in contact with moist subsoil or reaches into the underground water table. A more detailed discussion about the concept of grounding is provided in Appendix A.

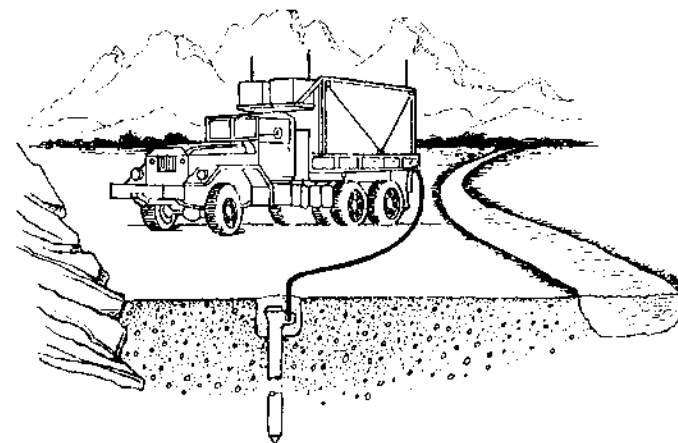

Figure 1 – Earth grounding of a communications shelter

It is important to note that earth grounding is only a part of the total ground system. Equally important to the earth grounding system is the need to bond all

equipment and power supply enclosures through the equipment grounding conductor (green wire) or other bonding conductors, as well as the need to bond the power supply neutral circuit conductor to earth (known as system grounding; refer to Appendix A). Since the primary area of soldier involvement is in the area of earth grounding and bonding shelters, generators, and equipment using rods and straps, this will be the area of focus. For more information on the additional requirements associated with equipment grounding conductors and system grounding, refer to the list of sources detailed in Appendix B.

2. EARTH GROUNDING SYSTEM KEY COMPONENTS

The earth grounding system consists of three key elements that must all be properly incorporated. These elements are the grounding electrode conductor, the connection point, and the earth grounding electrode (see figure 2). Lack of attention to any of the three elements can create a weak link that could lead to a failure (refer to Appendix C for a discussion of “the threat” to earth grounding systems).

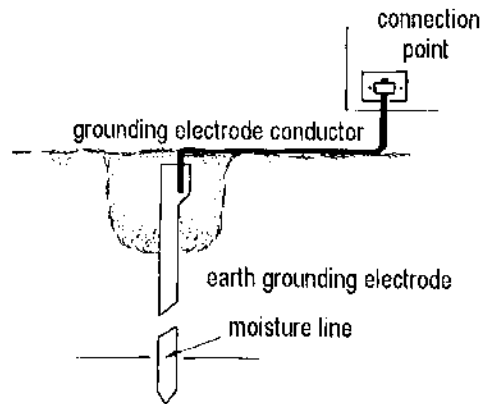

Figure 2 - Key elements of an earth grounding system

2.1 Grounding Electrode Conductors

The purpose of the grounding electrode conductor is to provide a low impedance path between the equipment noncurrent-carrying metal parts (enclosure) and the earth. The term “low impedance” is used, which covers both resistance (which is independent of signal frequency) and reactance (resistance that changes with frequency). The importance of this can be best illustrated as follows: say that a properly sized grounding electrode conductor is provided which has a number of loops and sharp bends. This grounding path may show a low resistance reading using a resistance tester, and may indeed be

suitable for DC or 60 Hz (low frequency) related events. However, the loops and sharp bends will substantially increase the path’s impedance during higher frequency events such as lightning related transients (over 100,000 Hz) and signal noise. This example points out the reason why in some cases equipment grounding-related problems occur although a grounding electrode conductor is provided. Along with loops and sharp bends, other factors that affect path impedance include wire size, length, shape and surface area.

It’s important to consider the following when choosing and installing the grounding electrode conductor:

- 1) The conductor must be as large as possible: at least 6 AWG. This gives it the mechanical strength necessary to withstand the severe mechanical forces subjected during lightning strikes, as well as the everyday wear and tear (being kicked or stepped on, setup and teardown, etc.). Since high frequency currents tend to pass over the surface of conductors as opposed to through them, wires such as flat straps that have larger surface areas than round conductors can lessen path impedance.
- 2) The conductor should be copper or copper clad aluminum. Coatings on the wire (such as nickel) or insulation are acceptable and help to reduce corrosion. Steel or stainless steel cables can be used only temporarily (systems frequently on the move) and where frequently inspected for corrosion.
- 3) The conductor should be continuous between the equipment and earth grounding electrode; do not splice. Ensure that the conductor is not damaged or heavily corroded. If crimped or brazed connectors are provided at the conductor ends, check for damage or looseness.
- 4) Run the conductor as straight and short as possible. Grounding electrode conductors should always run in a downward direction; do not run the conductor up and over obstacles.
- 5) Minimize any twists, loops, or sharp bends. Remove any knots in the conductor. Any kinks should be straightened out. Uncorrected, such conditions will increase the conductor’s impedance and cause failures under certain circumstances.

2.2 Connections

Frequently, connection points can be the source of problems. Though grounding connections can “look” okay, they may fail if loose or corroded. It’s important to consider the following when connecting the grounding electrode conductor to the equipment or earth grounding electrode:

1) Clamp or bolt the connections tightly to prevent loosening over time. Use a lockwasher where nuts or bolts are used. Do not over-tighten the connection to the point where the conductor strands are damaged. When using a ground rod clamp (see figure 3, example at right), always have the clamp body compress the grounding electrode conductor against the rod. Using the clamp screw to compress the grounding electrode conductor against the ground rod will result in a bad connection.

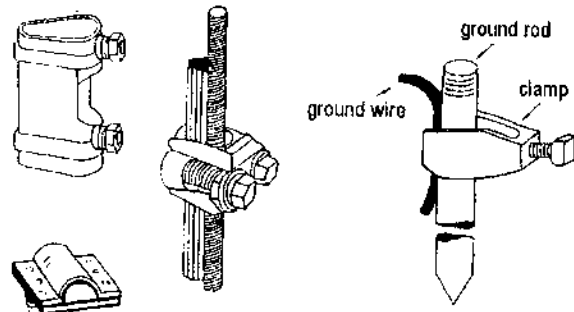

Figure 3 - Examples of suitable clamping devices

2) When attaching, ensure that the bonding surfaces are free of paint, corrosion, grease, or dirt.

3) Protect the connection points from corrosion and inspect regularly.

4) Connecting dissimilar metals, especially copper and aluminum or copper and galvanized parts (zinc plated surfaces or washers) can cause corrosion at the bonding point due to galvanic action. Avoid connecting such dissimilar metals together. Otherwise, inspect frequently and clean as necessary.

5) Never twist or tie a ground wire around a ground rod. If a bolt is not provided and a clamp is not available, the ground strap should be bound to the ground rod with at least 24 tightly wound turns of stripped telephone wire or other bare wire (see figure 4). This connection should then be taped to block out moisture. Use this method for a temporary connection until you can find a clamp.

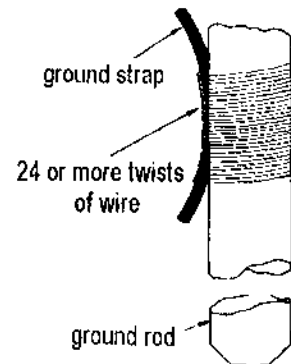

Figure 4 - Temporary connection

6) Replacement ground rod clamps, NSN 5975-01-034-8882, can be obtained for the 8-foot long, 1/2-inch thick ground rod (see figure 5). Note that these clamps cannot be used with the thicker, 6-foot ground rod.



Figure 5 - Clamp for 1/2-inch thick rod

7) If the thumb screw provided on the standard 6-ft ground rod becomes damaged, it can be replaced with a nut, bolt, and washer. Alternatively, a grounding clamp can be used, NSN 5999-00-496-5834 (see figure 6). When using such a clamp with a strap-type conductor having fine strands (as typically provided with the 6-foot ground rod), it's preferred to clamp the strap directly to the rod rather than using the top screw terminal, to minimize damage and kinks in the strap.

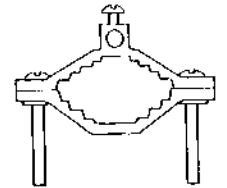

Figure 6 - Clamp for 5/8-inch thick rod

8) Hose clamps can only be used as a temporary measure if no other clamp is available. However, you should obtain a proper grounding clamp as hose clamps can fail under certain circumstances.

2.3 Earth Ground Electrode:

Various types of electrodes are used to establish an interface with the earth ground. The most commonly used electrode is the ground rod, which is available in various lengths and configurations. Under certain conditions, a good earth ground can be achieved by connecting to existing objects such as a buried metal pipe or the steel frame of a building. Where poor soil conditions exist, other methods and combinations of methods are required, which will be discussed later. The following is a description of some of the typical earth grounding electrodes that are used:

1) Ground Rod - Two are available in the Army inventory: the 8-foot ground rod, NSN 5975-00-878-3791, or the 6-foot ground rod, NSN 5975-00-224-5260 (see figure 7). The 6-foot rod comes in a single section, whereas the 8-foot rod is a three-section rod. Ground rods can be installed using a sledgehammer or, in the case of the sectional rod, a slide hammer (NSN 5120-01-013-1676).

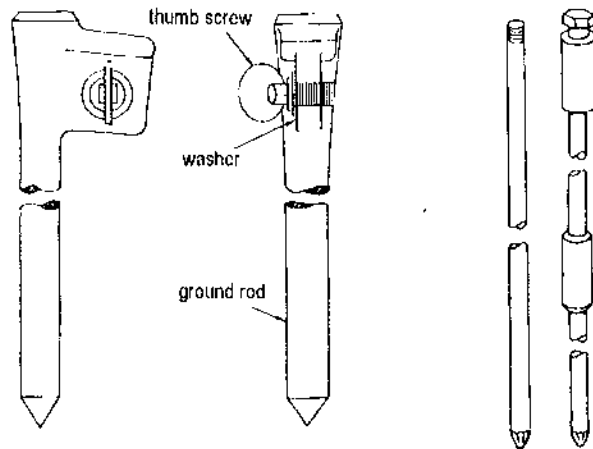

Figure 7 - 6-foot and 8-foot ground rods

2) Grounding plates - Though more difficult to install, plates can achieve very low earth resistance values. The plates must have at least 2 square feet of surface contact with ground (i.e., front and back of a 1 ft x 1 ft plate; see figure 8). Such a plate would have a 50% larger surface area than that of the 8-foot ground rod listed above. Plates should be a minimum of 1/4-inch thick if iron or steel, or 1/16-inch thick if nonferrous. Do not use aluminum because it quickly oxidizes and greatly increases resistance to earth.

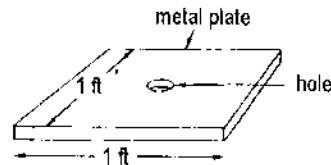

Figure 8 - Grounding plate

3) Surface Wire Grounding Kit (SWGK) - Also known as the Surface Wire Ground System, it was designed primarily for use with systems requiring high mobility/quick installation and teardown operation. It consists of 15 ten-inch stakes installed in a circular pattern and interconnected with a 3/16-inch steel cable. The SWGK is available in the Army inventory under the official nomenclature of Grounding Kit, MK-2551 A/U, NSN: 5820-01-263-1760 (see figure 9).

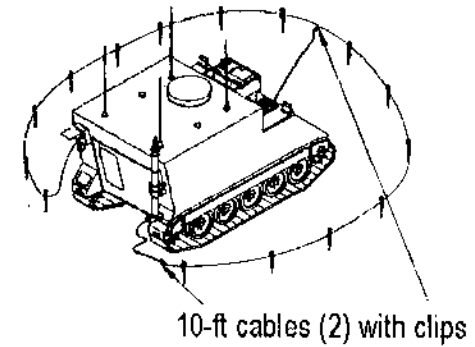

Figure 9 - A typical installation of the SWGK

4) Water plumbing - Traditionally, this was the preferred grounding electrode at fixed sites since the resistance to earth of the extensive water piping system was quite low. However, much plumbing is being changed over to or being coated with nonconductive materials, and therefore is no longer as reliable.

5) Buried tanks - Just as with water plumbing, buried tanks can provide an effective earth grounding terminal. However, tanks are often coated with or made of nonconductive materials which can reduce grounding effectiveness. Never use tanks with flammable contents.

6) Horizontal rods and/or conductors - Buried horizontal rods and/or conductors are an acceptable alternative where soil is shallow. Ideally, buried horizontal conductors should be at least 2 AWG and of copper material or copper-clad steel. Never use aluminum conductors as the earth grounding electrode because it quickly oxidizes and greatly increases resistance to earth.

7) Metal framework of buildings - often, a nearby steel frame building can serve as a suitable earth ground. Depending on the size of the metal building and the type of footings, a very low resistance to earth may exist. To ensure a suitable ground, all elements of the framework must be bonded well, especially between the steel frame and the footing steel reinforcement bars.

8) Grids - these consist of buried copper cables that form a network of squares over an entire area. This grounding system, though effective, is the least practical from a tactical standpoint, and will not be addressed.

3. SELECTION OF AN EARTH GROUNDING ELECTRODE

3.1 Important considerations

The choice of the best system to install will typically depend on the soil conditions (clay, loam, sand, rock, etc.) and the location's climate (tropics, deserts, mountains, arctic, etc.). Different types of soil have different electrical characteristics. Table 1 provides a brief summary of soil types, ground qualities, and suggested types of earth grounding electrodes.

Table 1 Soil Quality and Grounding

Type of Soil	Quality of Ground	Suggested Earth Grounding Electrode
Wet, organic soil	Very good	Ground rod, SWGK
Clay, loam, or shale	Good	Ground rod, SWGK or plate
Clay, loam, or shale mixed with gravel or sand	Poor	Buried pipes, building frame, or other metal object or a ground plate or several ground rods electrically connected together
Gravel, sand, or stone	Very Poor	Same as above *

* Under poor or very poor conditions, you'll have to take special steps to establish and maintain electrical conductivity explained in section 9.

3.2 General recommendations and precautions

- 1) Before digging any holes or installing any grounding electrodes, check for any underground electrical, gas, water, or other utility lines.
- 2) Never use metal natural gas lines for earth grounding. Never use buried tanks containing flammable liquids for earth grounding.
- 3) When choosing a location for the earth grounding electrode, keep it away from locations having normal pedestrian traffic. During an electrical storm or a fault condition, dangerous voltages induced at and near the earth grounding electrode could be hazardous to personnel (see Appendix D).
- 4) Aluminum should not be used as an earth grounding electrode.
- 5) Prior to connecting the earth grounding system, ensure that power to the system is off. This is not necessary if the system is initially self-powered, such as with an onboard generator.

6) Never lay system power cables or signal cables over the location of the earth grounding electrode, grounding electrode conductors, or SWGK cable. During a fault condition, step potentials at and near these components may be induced on collocated signal and power cables.

7) Install the earth grounding electrode at locations where ground will receive rain water (i.e., outside the drip line of shelters, etc.).

8) Where air conditioning units are operated near grounding electrodes, earth grounding resistance can be further improved by routing the air conditioner's condensation water to the grounding electrode location via a tube or hose.

9) Wear gloves to protect hands when handling or inspecting grounding electrodes, conductors, and connections. Wear safety goggles when driving ground rods to protect from flying metal chips.

10) Where any excavation is done, such as for ground plates or buried conductors, always add water when back-filling. This will help to compact the soil and ensure good soil contact with the electrode.

4. GROUND ROD INSTALLATION

Take the following steps when installing a ground rod:

- a. Clean the rod to remove all grease, oil or paint. Wear a safety glove to protect your hand from sharp metal fragments.
- b. Dig a hole at least 12 inches deep and 36 inches across.
- c. Drive the rod through to the moist subsoil. The ground rod should be installed straight if possible, but can be installed up to an angle of 45 degrees. Allow about 3 inches of the rod to protrude above the bottom of the hole. When installing a multiple section ground rod, ensure that top section is tight against the lower rod to prevent damage to the coupling sleeve threads. Similarly, the driving bolt should be tight against the lower rod (see figure 10). Be careful not to hit the threaded end of the rod section with the hammer, or damage the threads in any other way. A slide hammer (NSN 5120-01-013-1676) can make the task of installing and pulling out a multiple section ground rod easier and safer.
- d. After the ground rod is in place, connect the rod to the equipment or shelter using a ground strap or other suitable grounding electrode conductor. Connect the ground strap to the ground rod using the provided terminal screw. If your ground rod has no terminal screw or if it is missing or broken, connect the ground strap with a tight-fitting clamp, or as otherwise outlined in section 2.2.

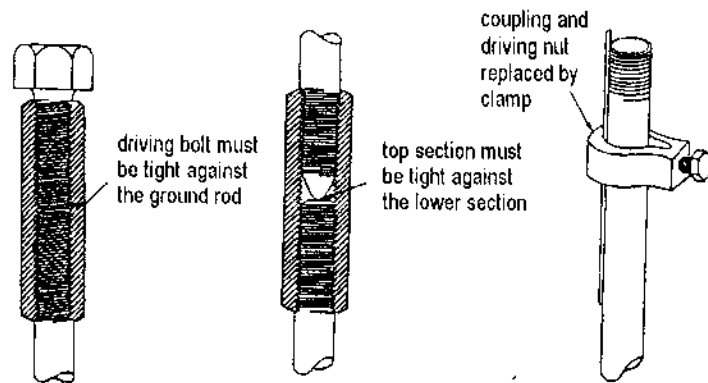

Figure 10 - Ground rod components and assembly

e. After one end of the ground strap or conductor is connected to the ground rod, connect the other end to the ground lug on the shelter or equipment. Keep the strap or conductor as short and straight as possible. Make sure that there are no loops or knots in the ground strap or conductor. See that all connections are clean and tight.

f. Fill the hole with water, and let it soak in. Then fill the hole with soil. Add water as often as needed to keep the soil moist around the ground rod. Check the grounding electrode conductor and connections every day and keep them clean and tight.

5. SURFACE WIRE GROUNDING KIT (SWGK) INSTALLATION

In many cases, the SWGK has proven to have a lower resistance to earth than that of a grounding rod. However, there is concern that the SWGK may have greater step potentials than a properly installed ground rod. For this reason, the SWGK is primarily approved for use with vehicle mounted systems, antenna masts, and trailers. Further instructions are available in TM 11-5820-1118-12&P.

a. Remove the SWGK from the bag and lay it in a circular or "U" shaped pattern around the equipment without overlapping the cable. Inspect the components and make sure that they are clean and not damaged. Sharp bends and kinks must be avoided in the cable. An important step here is to maximize the spacing between the individual stakes. Wear gloves when handling the steel cable as loose strands can cause cuts. Attach the connector end of the cable to the equipment grounding lug.

b. Begin with the stake closest to the grounding stud. Pull the cable taut. Twist stake 30 to 45 degrees. Drive stake until top is flush with the ground. Continue until all stakes are driven into the ground. Driving the stakes fully into the ground and slightly twisting them helps to ensure a tight connection between the stakes and cable.

c. Attach the two jumper cables. Connect one from the front bumper of the vehicle to the center of the cable, and the other from the rear bumper to the end of the grounding cable. These cables are provided to improve SWGK survivability and performance during high current events associated with lightning. It is not necessary to scrape paint to improve clip contact in this case since, under high current conditions, the paint will vaporize. However, the grounding lug end must still be attached to a stud or other location free of paint.

6. GROUND PLATE INSTALLATION

Where soil conditions are poor or very dry, a ground plate may work better than a ground rod.

a. Select any clean, bare metal plate or sheet that's at least 2 square feet of surface contact with ground as described in section 2.3(2). Note that the larger the plate is, the lower the resistance will be to ground; this is important to consider where grounding in poor soil (some standards recommend a 3-foot by 3-foot plate). Select a metal bolt, nut and lock washer and drill a hole in the center of the plate just large enough for the bolt. Fasten an appropriate grounding electrode conductor to the plate. Make sure the connection is clean and tight.

b. Dig a hole so that the plate can be buried vertically at 5 feet below the surface (see figure 11). Though some procedures recommend installing the plate horizontally, vertical installation ensures good soil contact on both sides of the plates. Pour a mixture of water and salt into the soil around the plate to further increase soil conductivity if necessary. See section 9 for information on improving soil conductivity.

c. Connect the other end of the grounding electrode conductor to the equipment, keeping the path as straight as possible.

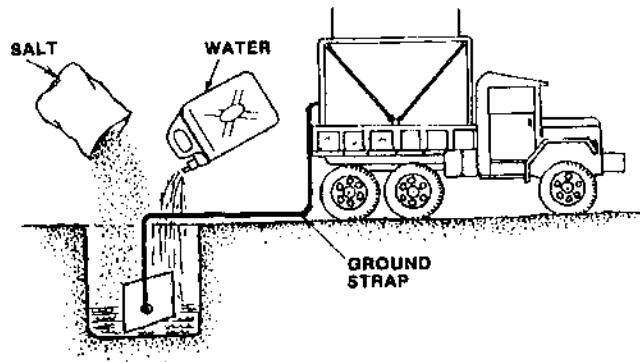

Figure 11 - Grounding plate installation

7. GROUNDING TO UNDERGROUND OBJECTS

Underground metal objects (buried metal pipes, steel frame building footings, metal poles, storage tanks) provide excellent grounding IF:

- (1) They are entirely buried at least two and a half feet below the earth's surface.
- (2) They do not contain gasoline or other flammable liquids or gas.
- (3) It can be assured that the metal object is continuous and not coated with or made of nonconductive materials.
 - a. Connect the grounding electrode conductor to the underground metal object with a solid connection. Do not wrap or tie it on. Avoid sharp bends.
 - b. Use water plumbing only if it can be assured that at least 10 feet of continuous metal plumbing is in contact with the earth. The connection to the plumbing should be made within 5 feet of the point where it enters the ground, and should bypass any water metering equipment. Never use natural gas plumbing as a grounding electrode.
 - c. Earth grounding quality may have to be verified through testing. Refer to Appendix E describing a field ground test that can be conducted using standard items available in the field.

8. INSTALLING HORIZONTAL CONDUCTORS AND RODS

Where bedrock is near the surface of the earth, horizontal ground rods and conductors can be installed. Refer to section 10.4 for tips on selecting locations

for earth grounding.

- a. Dig a trench up to two and a half feet deep. If soil/terrain do not permit a deep trench, dig as deep as possible.
- b. Install the ground rod horizontally or at least ten feet of 2 AWG cable in the trench. Pour a mixture of water and salt into the soil around the conductor/rod to further increase soil conductivity (see section 9 for improving soil conductivity). Fill and pack the trench with dirt.
- c. If the soil has a poor quality, such as dry, sandy, or with gravel, a second ground rod or 20 feet of 2 AWG cable should be used. Since the length of a cable directly increases impedance, it is better to run two 10-foot conductors in separate directions rather than one 20-foot conductor.
- d. Where the soil depth does not permit a trench deeper than a foot, a loop conductor or radials (see section 10.1) should be installed in a trench around the perimeter of the equipment. Alternatively, use a SWGK if available.

9. IMPROVING SOIL CONDUCTIVITY

At sites where the soil quality is very poor or very dry, special steps need to be taken to enhance the soil conductivity near the earth grounding electrode. The first option is to drive the rod deep enough to reach the moist subsoil, if possible. Use a multiple-section rod assembly, possibly using an added section. If there is no moist subsoil or if the soil condition won't allow for deep penetration, drive the rod as deeply as you can and apply water at regular intervals to keep the soil moist. However, the best way to substantially improve the earth grounding electrode resistance is to use salt and water (see figure 12).

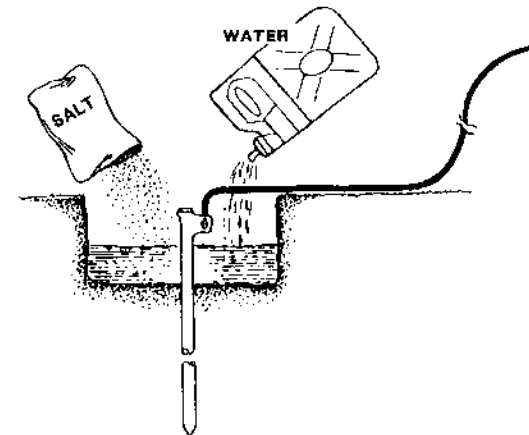

Figure 12 - Treatment of soil

Where salt water is required, use 1 pound of salt per gallon of water. Dig a shallow trench at a distance of 18 inches around the ground rod so that the liquid does not run off. To replace the salt that leaches into the soil, mix salt with the water at least once a week for the first four weeks of use. After the fourth week of use, add the mixture of salt and water at least once a month (Special measures apply to grounding in the desert; see paragraph 10.3). Optionally, salt can be placed in the trench and then covered, which will leach into the soil whenever it rains. From the standpoint of effectiveness and anti-corrosion qualities, the salt types listed below rank as follows:

- 1) Magnesium Sulfate
- 2) Copper Sulfate
- 3) Calcium Chloride
- 4) Sodium Chloride
- 5) Potassium Nitrate

Prior to using any such chemicals in the soil, you should verify that there are no environmental restrictions against using salt for such applications for the region or area. Keep in mind that even if salt is not available or permitted, applying water alone can still substantially improve soil conductivity.

10. TIPS FOR GROUNDING IN POOR SOIL CONDITIONS AND ENVIRONMENTS

One of the most important factors that must be stressed is that for any of the areas listed below, advanced thought must be given to the placement of equipment from an earth grounding perspective. Although mission requirements may predetermine areas for setup, locating equipment on one side of a camp as opposed to the other, or even moving the equipment a dozen feet can sometimes drastically improve earth grounding installation and effectiveness.

Where grounding resistance is poor, additional emphasis must be placed on the bonding of equipment enclosures, in order to limit hazardous voltages developed between such equipment enclosures which can be contacted by personnel (see section 11).

When your site does not have fine topsoil, clay, loam, or shale, you must compensate for poor electrical conductivity by taking the following applicable steps.

10.1 Use of multiple earth grounding electrodes

When a single ground rod provides a poor ground, drive in additional rods spaced ideally 4 rod lengths apart, but as a minimum at 2 rod lengths apart (see figure 13). The more rods you use, the better will be the electrical connection to the earth. Install them around the perimeter of your shelter or equipment. Connect all rods together and connect the closest rod to the shelter's power entry panel using the heaviest conductor you can find, preferably #6 AWG or larger bare copper cable. If possible, connect the other perimeter rods to other points on the shelter to further enhance the grounding. Treat the soil with a mixture of salt and water as explained in section 9.

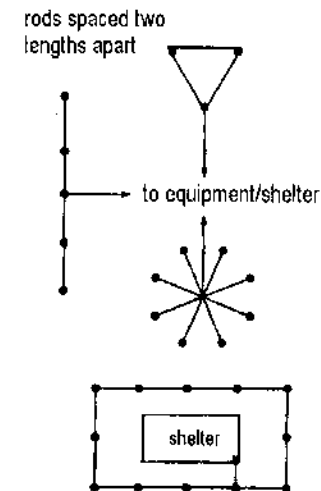

Figure 13 - Typical ground rod configurations

If a perimeter installation is impractical, you may install the rods in a star-ground configuration. Connect the center rod to the shelter and treat the soil as explained in section 9.

10.2 Poor soils mixed with sand or gravel

Use of multiple ground rods, ground plates, or other electrodes as specified in sections 4 to 8 is recommended. Where frequent on-the-move operations make it difficult to install and retrieve a ground rod, use the SWGK. To further enhance soil conductivity, a salt water mixture should be applied as discussed in section 9.

10.3 Desert

In desert environments, it is important for the ground rod to reach the water table below. One possibility is to install a sectional ground rod using added extensions to reach deeper into the soil. In addition, soil conductivity can be substantially improved by keeping the soil moist and by adding a salt water mixture as specified in section 9. When possible, route an air conditioner's condensation water to the grounding electrode location via a tube or hose. Ensure that collocated equipment is properly bonded as discussed in section 11.

Since sand is easy to excavate, use of grounding plates can be practical. The ground plates should be spaced at least 10 feet apart. Alternatively, a number of ground rods can be installed in parallel.

10.4 Mountainous terrain

The soil in mountainous areas is often only a few inches thick. Therefore, it is especially difficult and often impossible to penetrate to moist soil or a water table in the mountains. To properly ground your equipment, you must carefully select a site where a ground rod can be installed. Sites near a streambed will have higher levels of soil moisture and should be considered for grounding locations. Also try to choose a site which does not have rock outcroppings, which are indicative of shallow soil.

Where soil is shallow, earth grounding electrodes will have to be installed horizontally as detailed in section 8. The deeper that the electrode can be buried, the better the grounding protection. As trenches become shallower, step voltages at the ground surface will be greater, therefore increasing the potential hazard to personnel.

The location of personnel traffic areas needs to be considered when locating the earth grounding electrode, since step voltages during a lightning event could be very high. Personnel tents should be kept as far away from earth grounding electrodes as possible. Metal enclosures offer the best protection to personnel and, if possible, should be considered for sleeping quarters as opposed to tents (refer to Appendix F addressing personnel protection during electrical storms).

Grounding effectiveness can be substantially improved through the use of a salt-water mixture. In addition, salt can be placed along the trench just above the electrode, which will leach into the soil whenever it rains. Ensure that collocated equipment is adequately bonded as discussed in section 11.

10.5 Tropics

Install the ground rod or SWGK as described in sections 4 and 5. Because of

the constant high humidity, extra measures need to be taken to ensure that the strap connection at the equipment is clean and dry to prevent corrosion. Cover the connection of the ground with waterproof tape and check it every day.

10.6 Arctic

Cold substantially increases soil resistance and also, earth grounding impedance. Hence, it is important to drive ground rods or install ground plates below the area's frost line, if possible. Try to ground to an extension of a buried metal object such as an underground pipe or a building frame. If no buried object is available, drive in several ground rods as deeply as possible. Space them at least two rod lengths from each other. Alternatively, a trench can be dug to insert a horizontal rod or conductor, as discussed in section 8. The trench should be filled with salt water which will improve conductivity when frozen. Since ice and snow are very poor conductors of electricity, placing grounding electrodes in snow will not ground the system.

In cases where the frost line is too deep or where it isn't possible to ground the system, it is very important to ensure that all equipment is bonded together with grounding straps. This will help prevent potentials from developing between two pieces of equipment, as described in section 11.

11. BONDING OF COLLOCATED EQUIPMENT, SHELTERS AND GENERATORS

Personnel can sustain much worse injuries when contacting two metal surfaces at different potentials with bare hands (a low resistance path provided across the chest) than by contacting a surface energized to ground while wearing boots (a high resistance path to earth). For this reason, equipment and shelters located within arms length of each other (6-8 feet) must be bonded together to eliminate any hazardous voltages that may develop between them should a fault occur.

Shelter bonding should be done either by running a bonding conductor (at least 6 AWG) between the two shelter grounding terminals, or between the two ground rods provided for each shelter. Where only one ground rod is used for two shelters, having a grounding electrode conductor run from each shelter to the ground rod provides adequate bonding. This same requirement applies when two or more generators are collocated.

Don't forget to check remoted equipment for proper bonding. Often, radios and other Command & Control equipment are remoted from different shelters and systems to one location, such as inside of a tent (see figure 14). Since the earth grounding resistance for the different shelters can vary, potentials can exist between the remoted equipment. There have been cases where as much as 100v was measured between two radios mounted on the same table, spaced inches

apart, due to a fault located elsewhere! Make sure that such equipment is properly bonded together.

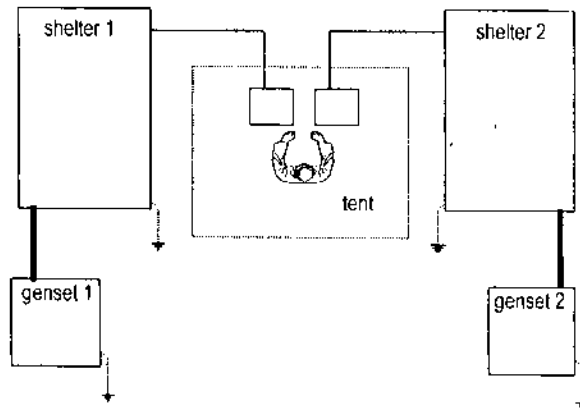

Figure 14 - Bonding here is necessary to protect the user.

During thunderstorms, lightning flashover or arcing can occur between two or more unconnected or poorly connected metal structures that are located close to each other. Flashover between objects can cause damage to the objects and cause lethal voltage on the ground in the vicinity of these objects. To avoid lightning flashover, make sure that equipment and other metal structures (fences, masts, sheds, etc.) located within 8 feet of each other are bonded together using a heavy copper cable, at least 6 AWG. The cable lengths should be as short and as straight as practical.

Interconnecting the ground rods for different shelters helps to create an earth grounding electrode system having an overall lower grounding resistance, and results in other benefits as well. Therefore, where electronic equipment shelters are located within 25 feet of each other, it is recommended that the individual earth grounding electrodes be bonded together using a heavy copper conductor (6 AWG minimum) run along the ground (see figure 15).

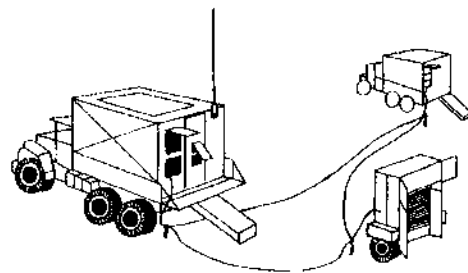

Figure 15 - Interconnection of earth grounding electrodes for collocated equipment

It's important to note that the Equipment Grounding Conductor (the green wire provided in the power cables) is sized to handle power related faults. The equipment grounding conductor is typically adequate to keep surfaces grounded during a power fault, and will also discharge some of the current during minor lightning related events. However, its small relative size and the way it's run (twists, turns, kinks, etc.) can create a higher impedance path that can fail during a lightning event. For this reason, collocated shelters should be interconnected using an independent bonding conductor as described above. The equipment grounding conductor should not be relied upon for such purposes.

12. HOW GOOD IS A GOOD EARTH GROUND REFERENCE?

When it comes to earth grounding installation, the greater the effort that is applied - the greater the level of safety that is obtained. It is this greater level of safety that can make the difference between a soldier receiving a shock or being electrocuted. The Army Safety Management Information System lists a number of accidents where improper grounding contributed to fatalities. On the other hand, reports also exist where soldiers walked away unharmed because proper and effective grounding limited the hazardous voltages contacted by the soldier during the fault condition.

It is difficult to assign a specific resistance value that must always be achieved. Various codes and handbooks recommend anywhere from 10 to 25 ohms resistance. MIL-HDBK-419, Handbook of Grounding, Bonding, and Shielding recommends an earth grounding resistance of 10 ohms for tactical, mobile systems. However, experience has shown that this requirement is often difficult to achieve in a high-mobility, tactical environment with only one or two ground rods installed. When making the decision as to how extensive the earth grounding electrode system should be, consideration needs to be given to the specific mission scenario, location, and environment. As a goal, one should strive to achieve the 10 ohm grounding resistance when possible. Table 2 lists tradeoffs that should be considered when making a decision.

Although the equipment operator should always strive to implement an effective earth grounding system, there will be situations where either due to mission or poor soil conditions, a good earth ground reference cannot be achieved. When this becomes the case, greater emphasis must be placed on ensuring that all equipment enclosures are bonded to each other and to the power supply through equipment grounding conductors and other bonding straps. A single point bond must be made at the power source between the equipment grounding conductor and neutral conductor. This will help to limit shock hazards between equipment during a fault condition (refer to appendix A).

Note that the decision concerning the extent of the earth grounding system does not bypass the requirements for proper earth grounding conductor installation or connections.

Table 2 Grounding System Tradeoffs

Install an extensive earth grounding system	Install the minimum earth grounding system
Mission requires equipment to stay in one place for a longer time (days, weeks)	Equipment must move frequently (daily)
Equipment is very complex, is collocated with other systems and interconnected to many other systems	System is primarily stand-alone
Extremely expensive equipment or mission critical (uninterrupted operation required)	Lower cost equipment or having a lower mission priority (can be interrupted)
Equipment susceptible to noise, may be subjected to electromagnetic interference (electronic warfare)	Equipment typically not affected by electronic noise or not subjected to electronic warfare
Equipment communications range needs improvement	Equipment communications range is suitable
Soil has very poor electrical quality	Soil has very good electrical quality
Site area has a high lightning risk	Site area has a low lightning risk

13. LIGHTNING PROTECTION

Two aspects need to be considered: personnel protection and equipment protection. Appendix F contains some guidance for personal protection during thunderstorms.

13.1 Basics of Operation

To understand how the lightning protection system operates, we'll examine how lightning interacts with the ground and how it attaches to objects on the ground. Most lightning that reaches the ground (over 90%) is negatively charged. It begins to intercept the ground by lowering a stepped leader; a precursor to the actual lightning discharge. This leader progresses in steps toward the ground and is comprised of electric charge. It completes this process in a length of time measured in tens of milliseconds. Below the leader is a region of very high electric field. Although the leader is very faintly luminous, chances are it will not be visible; the only indication you might have is noticing your hair standing on end. It is also possible that there will be no warning of an approaching leader. This is a consequence of the high electric field developed under the leader. As the leader approaches the earth, the high electric field under the stepped leader induces objects on the ground to emit leaders of opposite polarity charge. Since opposite charges attract, these leaders eventually connect and the actual current discharge associated with lightning begins. The process is illustrated in figure 16.

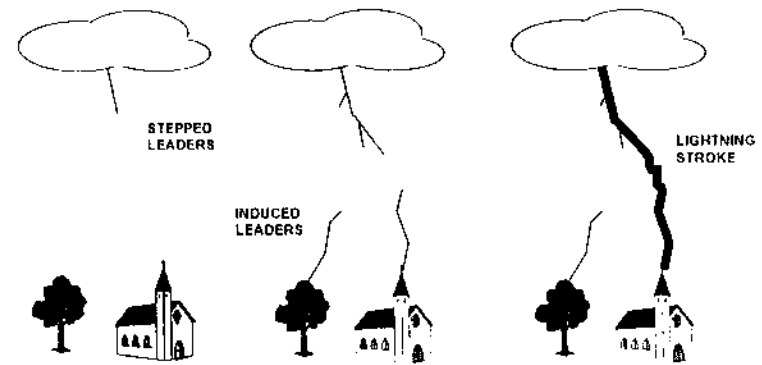

Figure 16 – Lightning propagation

Metallic objects electrically connected to the ground that are comparatively sharp emit the leader better than other objects such as trees and people. Taller objects generally have an advantage since they are closer to the stepped leader and begin to emit their own leader sooner. This is the primary principle of operation of a conventional lightning protection system.

This method of lightning protection is a "collector-diverter" concept consisting of three basic subsystems. The air terminal system forms the uppermost component. This may be a collection of metal terminals, sometimes called lightning rods, or an overhead wire or possibly just a metallic component of a structure. All are bonded together by heavy wire or similar conductors. The bottom section is the earth electrode system, most often provided by a ground rod. It is responsible for effective charge injection into the earth; away from structures. The system that connects the earth electrode and the air terminal is the down conductor system. Down conductors consist of heavy (usually copper wire) of approximately #2 AWG or larger, depending on the application. It is possible to use smaller conductors, but the risk of failure increases (risk of failure is approximately 10-15% for #6 AWG wire).

Contrary to some beliefs, the lightning protection system does not prevent lightning. Rather, it works by collecting the lightning stroke and diverting the electrical energy, in a controlled fashion, to earth. The air terminal is designed to intercept the lightning leader propagating from the cloud by providing an upward propagating leader. A preferred path is then established with the down conductor and earth electrode system. The lightning current is then dissipated into the earth.

The concept of a "protected zone" is often attached to lightning protection systems. In our context, we can define this as the area in which the lightning event has a high probability of being intercepted by the lightning protection

system. For the purposes of tactical systems, the zone protected forms a cone from the tip of the air terminal down to a distance on the ground equal to the height of the air terminal. This approximation is not valid for structures exceeding 50 feet in height.

The lightning protection system in its simplest form consists of a single air terminal, down conductor and ground electrode (ground rod). This is often seen in tactical antenna mast applications. Another common field installation is use of an overhead wire connected to ground rods. In this case the air terminal and the down conductor are really the same. Other configurations are possible.

13.2 When Do I Install Lightning Protection?

Obviously if the structure or system has been hit by lightning more than once, it is probably a strong candidate for lightning protection. As you can see from the explanation above, it is entirely possible (and probable) that lightning may strike twice in the same place. Otherwise examine the risk associated with operating the system in your particular location. Use table 3 to determine the risk and what to do. Assign higher scores to the statements that apply.

Table 3 Lightning Protection Risk Assessment

FACTOR	SCORE		
	(disagree - agree)		
System is critical to mission, uninterrupted operation is required.	1	2	3
Location is on high ground, unprotected by terrain features or trees.	1	2	3
A lightning strike to this location will cause injury to personnel (e.g., the system or structure is frequently occupied).	1	2	3
Construction of system/structure is mainly nonmetallic.	1	2	3
Structure/system is taller than other nearby structures.	1	2	3
Structure/system houses flammables, gases, or ammunition.	1	2	3
There are more than 4 thunderstorms with lightning every month.	1	2	3

Add the results. If the number is 18 or greater, lightning protection is a priority for that location. If greater than 14 but less than 18, the location is a strong candidate. If between 10 and 14 there is risk, but it is comparatively low. Scores between 7 and 10 indicate minimal risk.

14. LIGHTNING PROTECTION SYSTEMS - CONSIDERATIONS, EXAMPLES AND APPLICATIONS

The first consideration in lightning protection for tactical systems is terrain. In general, if systems can be placed equal in height or lower than their surroundings, this will somewhat lower the risk of being directly struck by lightning. A good example is the placement of antenna masts. If the antenna mast is deployed in a heavy forest, the probability of the mast getting directly struck will be considerably lower as there is a higher probability of the lightning striking trees.

Lightning protection systems help minimize damage to equipment/property that would otherwise be sustained if lightning followed a random path to ground. However, despite the physical protection that lightning protection systems afford, electric and magnetic fields from lightning current can still damage equipment, as can the voltage surges that these fields induce on other electrical conductors. Keep critical equipment and other signal or power distribution conductors as far away as possible from lightning protection system components.

The following examples of lightning protection systems for mobile, tactical systems are provided for guidance.

14.1 Lightning Protective Mast

A field expedient used successfully is deploying a mast or wooden pole with a lightning protection system. This provides a circular protective zone on the ground equal to the height of the mast. Recall that since the protective zone is conical, structures near the mast that extend outside of the protected zone are at a higher risk of getting struck. This is best used to protect a small area where there may be several vehicles or shelters. The ground rod or other electrode system must be placed close to the mast, as the down conductor may not be run along the ground. In this sense it is not suited to places with high personnel traffic. See figures 17 and 18 for details.

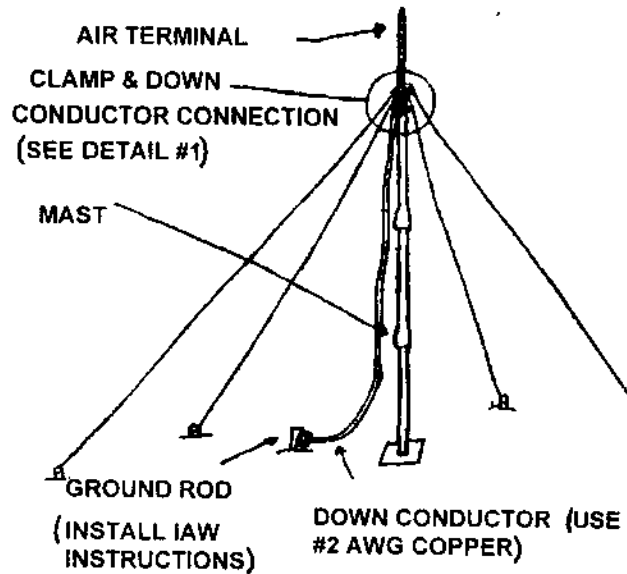

SUGGESTED MATERIALS:

MAST: OE-254 (AB-1244) MAST OR WOODEN TELEPHONE POLE.
WARNING: DO NOT USE MASTS UNTESTED FOR WINDLOADING.

GUY WIRES SHOULD MAKE MINIMUM 45 DEGREE ANGLE WITH MAST - INSTALL IAW TM INSTRUCTIONS.

AIR TERMINAL: 1 OR 2 SECTIONS OF GROUND ROD, NSN 5975-00-596-2324.

GROUND ROD: NSN 5975-00-596-2324 OR 5820-01-263-1760 OR EQUIVALENT.

Figure 17 - Field expedient lightning protection mast

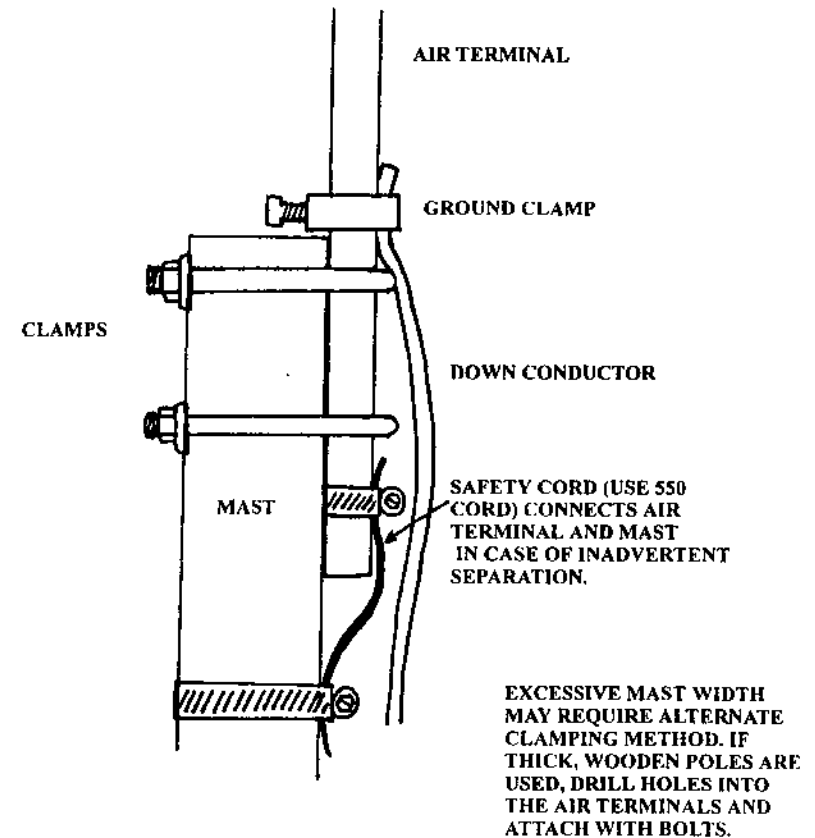

Figure 18 - Detail #1

14.2 Overhead Wire

Another successful lightning protection system is the overhead wire. This system protects a larger area. Its protected zone is shaped like a tent with the peak at the overhead wire. Note that the wire must be six to eight feet above the protected structure due to the danger of flashover. Making the wire too long will increase the chance of flashover due to inductive loading on the wire. A realistic maximum wire length is 60 to 80 feet. See figures 19 and 20 for details.

Note that if the protected structure is metallic, it must be grounded and bonded to the lightning protective grounds (refer to section 15).

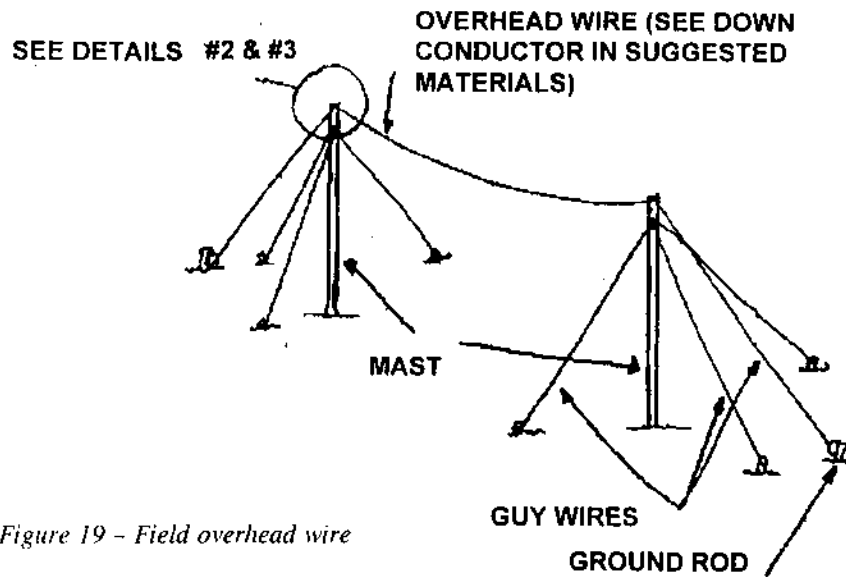

Figure 19 - Field overhead wire

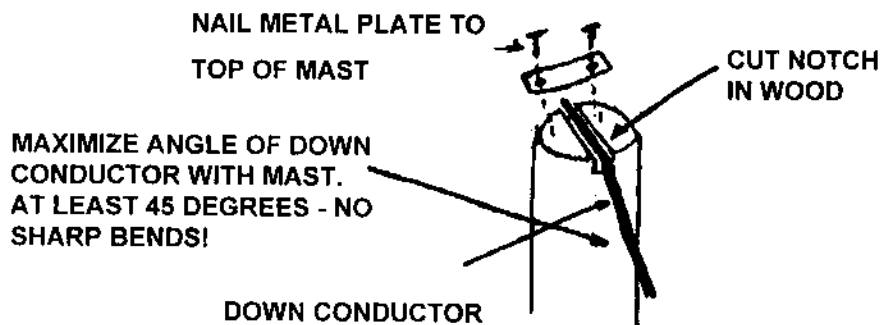
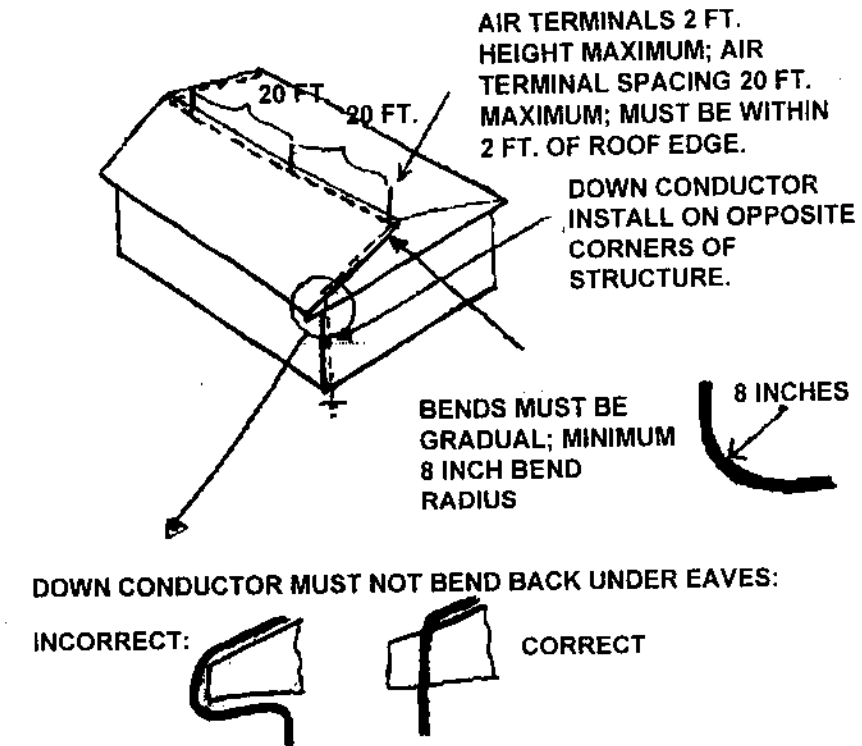

Figure 20 - Detail #2

14.3 Basic Structural Installation

It is possible to install air terminals directly to a structure (see figure 21). In this case, the air terminals must be bonded together. There must not be any "dead ends" on the down conductor. Run each end down, as illustrated, to the earth electrode. If the width of the roof exceeds 50 feet, air terminals need to be installed on the roof perimeter. Do not use these guidelines for structures exceeding 50 feet in height. Do not use these guidelines for large structures or complex roof structures. Careful engineering of protection systems must be accomplished in these cases. Bonding of all-metal roofs to ground is also a good method to protect against lightning, but there is a risk of burn-through if the metal is less than 3/16-inch thick.



COMMERCIAL CONNECTOR BLOCKS ARE USUALLY USED TO MOUNT AIR TERMINALS TO STRUCTURES, BUT APPROPRIATE EXPEDIENTS COULD BE USED.

Figure 21 - Structural protection

14.4 Signal Entry Protection

A "loop" or sharp bend can be made in signal coaxial cables and the outer conductor connected to ground at that point. Lightning current is most likely to flashover at that point in the conductor. If the down conductor is connected to ground as straight as possible at the connection point, lightning will find this as a preferred path to ground, diverting the bulk of the current from the signal entry. Although the signal cable would be lost as a result of a direct lightning strike, this type of an arrangement may help to protect the interconnected radio and electronics. See figure 22 for details.

Check if the system/equipment has surge protection before doing this; a better arrangement may be built into your system. This arrangement may also be used in the case where a stand-alone radio is connected to an antenna mast. Use a connector at the loop point and bond the connector to ground. Bond the ground system used here to the main grounding system of the shelter or structure protected, if applicable. Note that cutting into the insulation may void any contractor warranties or cause damage to the coax, and should therefore only be attempted as a last resort.

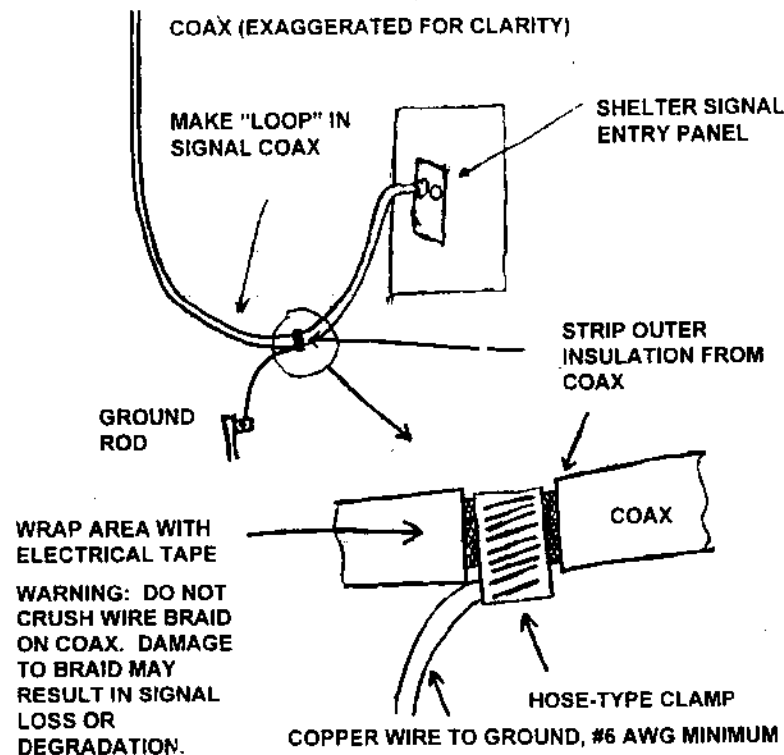

Figure 22 - Expedient signal entry protection

14.5 Fluid/Gas Storage Tanks (Permanent/Semipermanent Installation)

Ground tanks to an earth electrode system IAW previous instructions and bond to nearby metal objects. This will minimize the possibility of flashover or arcing which has the potential to ignite fumes from flammable liquids or residual gases (see section 15).

14.6 Summary

Major principles and simple examples of basic lightning protection for field applications have been discussed. These cover the major portion of field applications. If more complex applications arise ASK FOR TECHNICAL ADVICE (see page ii). The examples given are valid within the restrictions of the drawings but may not be applicable to large complex systems or structures.

15. BONDING FOR LIGHTNING PROTECTION

Grounding and electrically bonding the lightning protection system is a critical aspect of protection. By following the steps in this pamphlet, you will be able to establish an effective ground for lightning protection purposes. A very low resistance is desirable for lightning protection; 25 ohms should be a maximum value for lightning protection grounds. Even a fairly low resistance can cause the development of several million volts of potential on the lightning system components.

Bonding to prevent flashover of the lightning current is also necessary. If the current carrying parts of the lightning protection system are in the vicinity of grounded metal parts (a shelter, fuel tank or similar item) the lightning may jump, or flashover to the grounded metal part. To prevent this, the lightning protection system ground and the grounding system must be electrically bonded to eliminate severe potential differences that cause flashover.

Use of the same ground rod for the power ground and the lightning protection ground is not recommended. It is far better to use a separate ground for the lightning protection system that is bonded to the power ground. The two reasons for this is that the length of the lightning protection system down conductor must be minimized and that you want most of the lightning current diverted into the earth before it reaches the rest of the grounding system. If the system has no separate lightning protection system (as in a common shelter), then the single ground rod will suffice. Refer to section 11 of this pamphlet for additional information on bonding of collocated equipment.

APPENDIX A

GROUNDING SYSTEMS AND THE CONFUSION ABOUT GROUNDING

From a safety standpoint, the functions of the grounding system can be placed in two categories. One function is to provide a low impedance path between all equipment and power supply noncurrent-carrying metal parts (enclosures, etc.), as well as provide a bond between these parts and the power supply neutral conductor back at the power supply. Bonding of enclosures is carried out through the use of an equipment grounding conductor (the green wire provided with power cables), and bonding between the grounding and neutral conductor is provided through the main bonding jumper. As you can see in figure 23, the low impedance path provided by these conductors would permit sufficient current to flow back to the power supply to open any circuit breaker protection in the event of a ground fault. The equipment grounding conductor also helps to keep the voltage developed between collocated equipment enclosures down during a fault. In these cases, the equipment grounding conductor acts more like a "bonding" conductor, in that its main function is to bond noncurrent-carrying parts back to the power supply rather than bond them to earth.

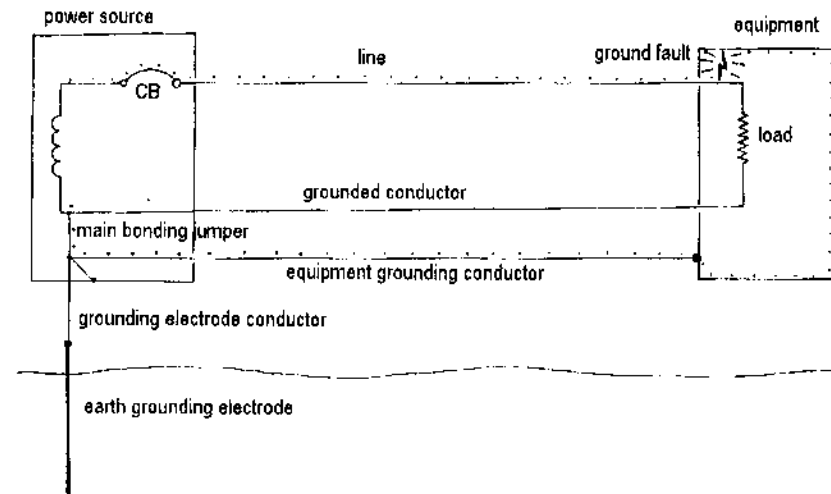

Figure 23 - Low impedance path provided by the EGC during a fault

The second function involves keeping the equipment enclosures or other noncurrent-carrying metal parts at earth potential, to provide a preferred discharge path to earth for surges, and provide a ground reference plane for communications signals. As seen in figure 23, this is provided by the grounding

electrode conductor and the earth grounding electrode. The earth grounding system protects against hazardous voltages between enclosures and earth ground developed as a result of power surges, lightning, and other faults.

Confusion stems from the fact that in many cases, the equipment grounding conductor not only bonds the equipment back to the power supply, but also earth-grounds the equipment through the grounding electrode conductor provided back at the power supply. Both functions can be suitably carried out by the equipment grounding conductor for "simpler" equipment such as appliances, tools, and individual equipment. However, as systems become larger, more complicated, more sensitive to EMP, have more power sources or are interconnected via numerous control and signal cables, faults can occur just about anywhere which could follow unpredictable paths over which there is no control (see figure 24). For complex systems, such as shelters, additional equipment grounding electrodes and conductors should be installed to ensure that under fault conditions, hazardous voltages cannot be developed on enclosures relative to earth ground.

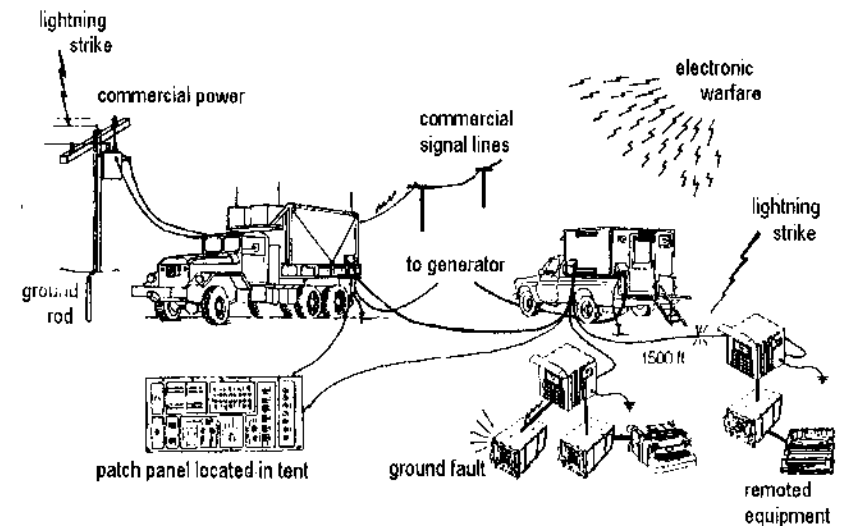

Figure 24 - Complex systems can have multiple sources and paths for faults

It is important to stress that earth grounding is only part of the overall grounding system, and is not a substitute for the equipment grounding conductor or the main bonding jumper. Since power faults always follow a path back to the power source, and since the earth is a poor conductor of electricity, sufficient current will not flow back to the power supply to clear any circuit breaker protection (see figure 25). However, the limited current that will flow through the earth will cause equipment surfaces to have a raised voltage. The result is a

shelter or piece of equipment that may be functioning without any visible signs of a problem and which has an energized surface – a very hazardous condition. A low impedance path must be provided back to the power source via the equipment grounding conductor to avoid this condition. Refer to Appendix G for more information on troubleshooting energized equipment surfaces.

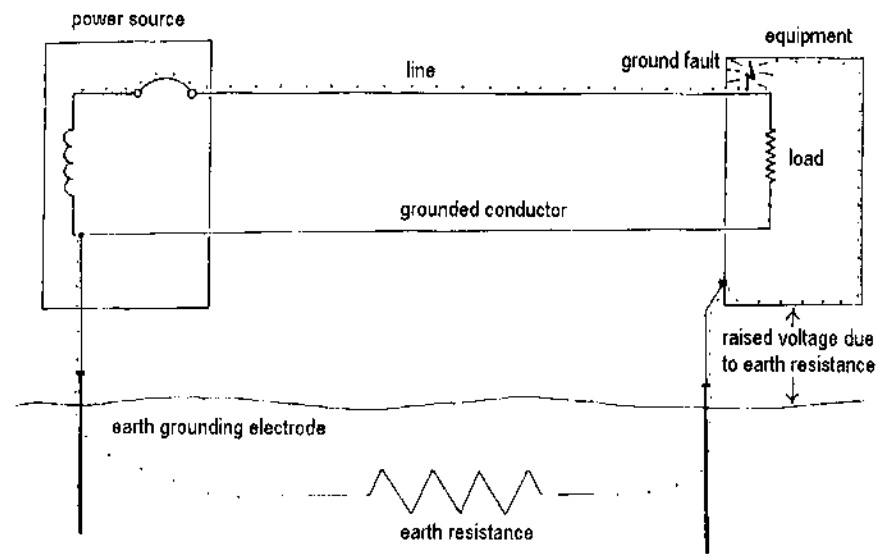

Figure 25 - Soil provides a poor impedance path; circuit breaker will not trip.

During the development of equipment, the system designer is heavily involved in ensuring that equipment grounding conductors are incorporated and suitably sized; the designer does not get involved with the particulars of Earth Grounding. However, the tables turn in the field in that the soldier's involvement with equipment grounding conductors is very limited (making sure the "green" wire is connected at the generator, etc.), and much work is placed on installing grounding electrode conductors and earth grounding electrodes, and bonding equipment. As a result, this pamphlet concentrates on proper earth grounding procedures which are of primary concern to the soldier. Additional information on equipment grounding conductors and system/neutral grounding is available in documents listed in Appendix B.

APPENDIX B

ADDITIONAL DOCUMENTATION AND REFERENCES

CECOM TR-93-1 Lightning Protection System Design.

CECOM TR-94-8 Engineering Application Notes: Grounding Kit, MK-2551 A/U (Surface Wire Grounding Kit).

FM 11-487-4 Installation Practices: Communications Systems Grounding, Bonding, and Shielding.

MIL-HDBK-419 Grounding, Bonding, and Shielding for Electronic Equipments and Facilities.

NFPA 70 National Electrical Code (NEC).

NFPA 780 Installation of Lightning Protection Systems.

TB 43-0125 Installation of CE equipment: Hookup of Electrical Cables to Mobile Generator Sets on Fielded Equipment to meet Electrical Safety Standards.

TM 11-5820-1118-12&P Operator's and Unit Maintenance Manual Including Repair Parts and Special Tools List for Grounding Kit, MK-2551A/U.

THE THREAT

The worst event that an earth grounding system can sustain is a direct lightning strike. More often, equipment is subjected to and damaged by the strong electromagnetic fields created by a nearby lightning strike, or the brief electrical surge that can pass through signal lines. By installing the system with the anticipation of the "worst case event," it can be assured that the earth grounding system will function suitably for the other cases as well. Additionally, many of the factors that can lead to grounding system failure during a lightning strike can also be the source of problems for minor events such as system noise and communications effectiveness.

In order to get a true appreciation for what lightning is and what it can do, let us take a brief look. Lightning is an atmospheric event by which an electrical discharge occurs between the earth and sky. A single strike can be divided into four components. The first is characterized by an extremely short pulse that averages around 15,000 amps, but can go as high as 200,000 amps. This first pulse has an extremely fast rise time, from zero to peak current in microseconds, making it similar to a high frequency event. The next component is a very short transitional period of a few thousand amps that leads to the third component that's characterized by a steady current of a few hundred amps for up to 0.75 seconds. The last component is similar to the first component with about half the current peak. For the average lightning strike, these components are repeated 3 or 4 times, and have been measured up to 26 times in one event!

Now let's translate these components and events into what they do to the grounding system. During the first "pulse component," extremely high electromagnetic fields are developed. These fields can create strong mechanical effects on the conductors and bonding connections causing twisting, pulling, squeezing, and snapping. Any loose connections can be pulled apart quite easily at this point. The following two components are primarily responsible for heating. During these two components, enough current can be passed to raise the temperature of a wire a few hundred degrees. Any loose, corroded, or other connections having some resistance would melt at this point. Note how the first component can cause connections to loosen, which would then melt during the next "heating component." When considering the sheer magnitude of the event that occurs and that it's repeated a number of times, it becomes very clear that any single weak link in the grounding system could cause it to fail.

HAZARDS DUE TO STEP POTENTIALS

Lightning may impose a very high magnitude current pulse onto the earth ground electrode, which then sinks the current into the earth. During this process, current flows outward from the earth electrode. In figure 26, we illustrate a ground rod with a current flowing into it and then outward through surrounding cylindrical shells of earth. We know that each shell of earth has some electrical resistance. As the current flows through each resistive shell a voltage is developed on the surface of the earth. This is called the step potential or step voltage, or simply the voltage that can develop over the space of one step on the surface of the earth. The step voltage can be several thousand volts, which is enough to do serious injury, or even be lethal. If the person in this figure were unfortunate enough to be near a ground rod subject to a high current event like lightning, he would probably experience a momentary but very severe shock due to current travelling through his body from one foot to the other due to this voltage difference between his feet.

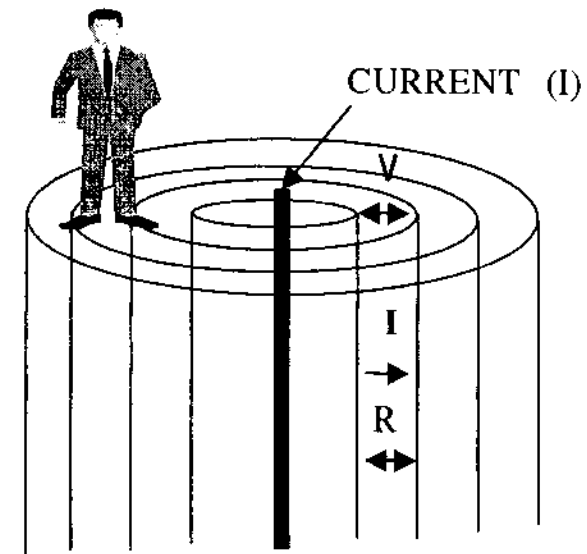

Figure 26 - Step potentials

Step potential is greatly reduced, in most cases, as one moves further from the ground rod.

There are a number of things that can be done to minimize the effect of step potentials. One is to minimize the resistance of the earth electrode, which can

be done through proper installation, use of a few interconnected electrodes, soil treatment, etc. In addition, burying the electrode (plates or deep rods) helps to reduce step potentials at the ground surface. One of the surest methods, however, is to keep personnel away from the grounding elements. Ground rods should be installed away from walk areas: at least 6 feet. It should be noted that a person lying on the ground near a grounding electrode can also experience severe shock; keep sleeping quarters away.

APPENDIX E

EARTH GROUNDING TEST

It is possible to conduct a quick test to make a rough measurement of the earth grounding electrode's resistance. You will need the following equipment:

- ✓ multimeter (two can be used).
- ✓ four lengths of wire, 12 AWG or larger, up to 70 feet long.
- ✓ 2 short grounding electrodes (copper or steel with 1/2- to 3/4-inch diameter and 2 feet long; a single section of a sectional ground rod works fine).
- ✓ at least four wire clamps (these can be the clip type or other type). Four terminals may also be needed to connect the wire to the multimeter if the multimeter doesn't have test clips.
- ✓ a hammer to drive the ground electrodes.
- ✓ an automobile or truck type battery, charged.
- ✓ a tape measure.

The basic procedure consists of creating a current loop (measured in step 1) through the earth grounding electrode under test and the outer current probe, and then measuring the voltage drop at 2/3 the distance from the earth grounding electrode. Dividing the measured voltage by the measured current will give the effective grounding resistance of the electrode under test.

Setup:

Place all of the probes in a straight line with respect to the earth grounding electrode being tested. Place the current probe about 60 feet away and the potential probe at 0.62 times this distance from the ground rod under test (about 36 feet). Drive in the current and potential probes about 1½ feet. Connect the wire as shown in figure 27.

Procedure:

1) Place current probe, the multimeter and the battery in series with the ground under test (see figure 27). It is important to place the probes in a straight line with respect to the ground rod under test. Record the current reading. Disconnect the battery.

Note: the accuracy of this test suffers if the measured current is less than 30 mA. Refer to figure 29 for additional information.

STEP 1

SET MULTIMETER FOR CURRENT READING
SET UP CIRCUIT AS SHOWN
TAKE CURRENT READING
DISCONNECT BATTERY

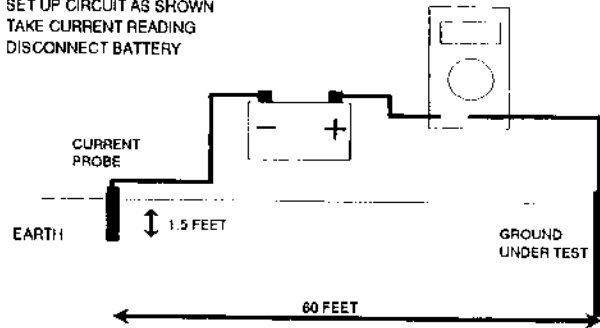

Figure 27 - Current measurement

- 2) Place the multimeter in series with the potential probe and the ground rod (see figure 28). Set the multimeter for a voltage reading.
- 3) Connect the battery in series with the current probe and the ground under test (see figure 28). Take a voltage reading between the potential probe and ground under test with the multimeter. Disconnect the battery.

STEP 2

SET MULTIMETER FOR VOLTAGE READING
SETUP CIRCUIT IN DIAGRAM - CONNECT BATTERY LAST
TAKE VOLTAGE READING
DISCONNECT BATTERY

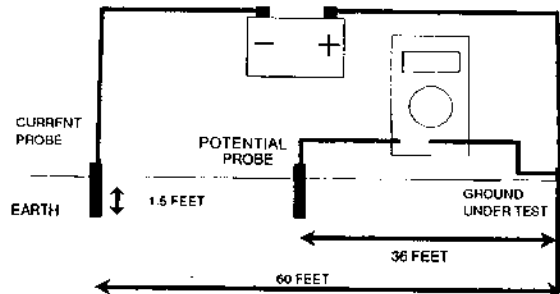

Figure 28 - Voltage measurement

- 4) Divide the voltage [volts] by the current [amperes] yielding resistance. This is the resistance of the ground under test. (Make sure the units are correct; the multimeter most likely will read in milliamperes, which is one thousandth of an ampere).

Limitations:

Although this procedure provides a good indication of grounding quality, some error is introduced since a DC power source is used. If accuracy is important, such as when conducting facility grounding certification, proper earth grounding test equipment must be used.

The probe distances specified in the setup section are based on testing of a single earth grounding electrode (ground rod, SWGK, etc.). If testing multiple electrodes, the probe distances should be increased.

As noted previously, the accuracy of this test suffers if the current measured in step 1 is less than 30 mA. Figure 29 describes a two-battery setup which will increase current flow.

SPECIAL CIRCUMSTANCES

A SINGLE BATTERY MAY NOT BE SUFFICIENT WHEN MEASURING HIGH RESISTANCE TYPE SOILS (DRY, SANDY, ROCKY, ETC). IF THE MULTIMETER READINGS ARE NOT STABLE, USE TWO BATTERIES IN SERIES AS SHOWN BELOW (NOTE PROPER POLARITY):

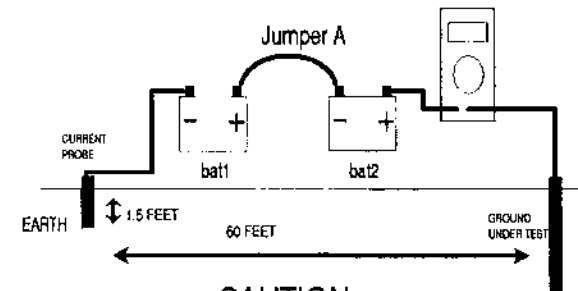

CAUTION

DO NOT EXCEED 30 VOLTS TOTAL ($V_{total} = V_{bat1} + V_{bat2}$)

TO FURTHER REDUCE THE POTENTIAL FOR SHOCK, CONNECT JUMPER A LAST BEFORE THE TEST, AND DISCONNECT JUMPER A FIRST AFTER THE TEST. THIS WILL LIMIT THE VOLTAGE BETWEEN ANY ACCESSIBLE PARTS AND GROUND TO THE VOLTAGE RATING OF A SINGLE BATTERY.

Figure 29 - Increasing current flow to improve accuracy

APPENDIX F

PERSONNEL PROTECTION FROM LIGHTNING

Always plan in advance for lightning safety if in an area of high risk or high lightning incidence (mountain ranges, etc.). The following guidance is based on information from NFPA 780.

1. Do not go outdoors or remain out during thunderstorms unless it is necessary. Seek shelter as follows:
 - a. dwellings or other buildings protected against lightning, like shelters.
 - b. underground shelters such as subways, tunnels, or caves.
 - c. large metal frame buildings.
 - d. large unprotected buildings.
 - e. enclosed automobiles, buses, and other vehicles with metal tops & bodies.
 - f. enclosed metal trains and street cars.
 - g. enclosed metal boats or ships.
 - h. boats which are protected against lightning.
 - i. city streets which may be shielded by nearby buildings.
2. If possible, avoid the following places which offer little or no protection:
 - a. small, unprotected buildings.
 - b. tents and temporary shelters.
 - c. automobiles with nonmetal top or open.
 - d. trailers which are nonmetal or open.
3. Certain locations are extremely hazardous during thunderstorms and should be avoided if at all possible. Approaching thunderstorms should be anticipated and the following locations avoided when storms are in the immediate vicinity:
 - a. hilltops and ridges.
 - b. areas on top of buildings.
 - c. open fields, parking lots, athletic fields, golf courses, tennis courts, etc.
 - d. Swimming pools, lakes and seashores.
 - e. near wire fences, clotheslines, overhead wires, and railroad tracks.
 - f. under isolated trees.
 - g. Avoid use of or contact with electrical appliances and plumbing fixtures near earth grounding systems. Also avoid using telephones; most lightning injuries occur from using phones during electrical storms.
4. If you are hopelessly isolated in an exposed area and you begin to feel your hair stand end on end (indicating that lightning is about to strike close by), squat, keeping your feet as close together as possible, and put your hands on your knees. Do not lie flat on the ground or place your hands on the ground.

APPENDIX G

ENERGIZED EQUIPMENT SURFACES CHECKS AND PRECAUTIONS

When operating equipment in a field environment, equipment surfaces can become energized due to electrical faults, or even as a result of normal operation due to leakage current, a dissimilar ground reference (see figure 14), etc. Prevention of energized surfaces is critical for electrical safety. Most often, if you setup the system IAW the TM, there will be no problem. However, difficulties often arise when several different systems are collocated and interconnected. The best defense is to examine and rehearse the proposed setup before going to the field specifically to identify electrical safety problems early. Qualified personnel can then fix the problem before it becomes a critical operational issue.

Key symptoms of energized equipment surfaces are a tingle or shock when touching the equipment, or seeing sparks when connecting grounded signal cables. Note that certain systems apply a DC power voltage over signal cables (less than 30 V) which can cause minor sparking. Verify that this is not the source of the sparking.

DANGER: Injury or Death can occur from electrical shock. Remove power to energized equipment immediately. If you are unqualified or unsure of how to diagnose electrical faults, call the appropriate level of maintenance.

All problems of this nature occur when the equipment surfaces intended to be grounded have some voltage difference compared with another grounded system, or with earth ground (see figure 30). Typically there is a problem with the Equipment Grounding Conductor (EGC), the green wire in the power supply cable, or a bonding conductor, and/or the power supply cable is connected improperly. The focus should therefore be on ensuring proper bonding (referencing all equipment to a common ground) which keeps collocated surfaces at the same potential. One of two things will happen once proper bonding is ensured: either the voltage will cease to be present on the system or a circuit breaker will open, indicating a fault condition. If the circuit breaker opens, it means that there is a fault. DO NOT attempt to bypass the circuit breaker.

Diagnosing grounding problems can be difficult for the average equipment user, especially in cases where many shelters on different power systems are collocated. Despite this, there are a few common sense checks that can be performed that may solve the problem. The steps listed below are not all-inclusive, and do not guarantee a resolution to the problem for every scenario. They are also presented in a manner that assumes that you have troubleshooting

experience with electrical equipment and systems. If you are unsure of any of the steps below, you must defer troubleshooting to a qualified maintainer.

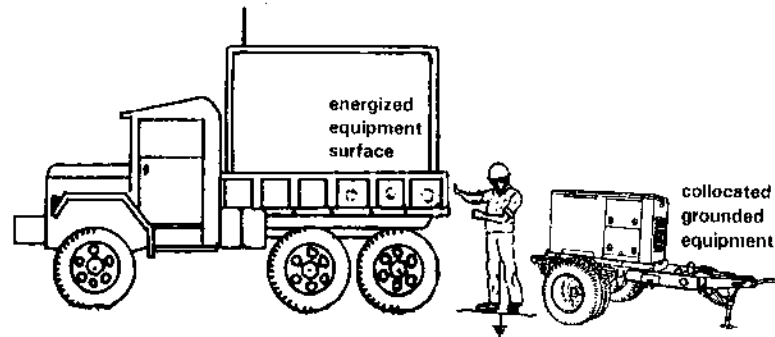

Figure 30 - Hazardous voltage between collocated equipment and/or to ground

FIRST, remove power to the equipment/shelter as close to the source of power as possible. The easiest way to do this is to open the circuit breakers on the system generator, or shut the generator down. This is essential to avoid shock hazards. For a piece of equipment in a tent, this may mean unplugging it from an outlet. If voltage is still present on the system, a shelter or piece of equipment that is still powered and that is interconnected may have a fault. Shut down all interconnected equipment that remains powered and inspect these as well.

With power deactivated, inspect the following and correct as necessary:

- 1) Ensure that collocated power systems (generators, etc.) have a common ground reference (see section 11).
- 2) If a shock was felt between two collocated pieces of equipment, ensure that they are adequately bonded (see section 11).
- 3) Verify that the equipment grounding conductor (green wire) is properly connected at the power source and/or any power distribution point.
- 4) Check and make sure that the power cable conductors are not miswired at the power source and/or power distribution point .
- 5) Check for visible signs of damage to the power cable, the connector, the connector pins, etc.

If the above checks do not reveal any problems, then it's possible that the power cable has a failure. A resistance check should be made of the power cable.

Each conductor should be tested end-to-end to ensure that it has a low resistance (less than 0.1 ohms). In addition, test each conductor to make sure that it measures a high resistance to any other conductor in the cable (greater than 1 megohm). Keep in mind that certain power cables may have multiple equipment grounding conductors which are supposed to be wired together. Refer to the equipment's technical manual for a schematic or a pinout diagram. If you are unsure of this procedure, refer it to a qualified maintainer.

Once the above checks have been performed, check if the equipment remains energized. This can be done by using a multimeter set to AC volts. Place the multimeter probes between the metal equipment case and the ground of the source of power (the generator, etc.). Placing the multimeter probes on a local EGC and the equipment case may not reveal anything because there will be no voltage difference between an energized case and energized EGC. It is also important to test with the multimeter probes between the metal equipment case and other adjacent metal surfaces (shelters, collocated equipment, etc.). Use care to not touch any metal surfaces of the equipment or test probes during the test. If there is any reading over 10 volts, a potential hazard remains, and further troubleshooting should be pursued.

APPENDIX H

DEFINITIONS: the National Electrical Code (NEC) uses the term "grounding" to describe different aspects of grounding, which can lead to confusion. This pamphlet uses the following terms and definitions:

Bonding - the permanent joining of metallic parts to form an electrically conductive path that will ensure electrical continuity and the capacity to conduct safely any current likely to be imposed.

Equipment Grounding Conductor - this conductor is used to tie all noncurrent-carrying parts or an equipment (enclosure, etc.) together and back to the power source. An example of an equipment grounding conductor is the green wire provided in a power cable. Unlike the grounded (neutral) conductor, it is intended to carry current only during a fault condition.

Earth Grounding - A conductive connection between an electrical circuit or equipment and the earth (the NEC calls this Grounding).

Earth Grounding Electrode - this is the actual element that contacts and makes a good reference to earth, and usually consists of a ground rod, buried plates, wires, pipes, etc. (the NEC calls this the grounding electrode).

Ground Fault - a fault condition where an ungrounded conductor (a "hot" wire, such as the black power line) shorts to a noncurrent-carrying metal part, such as the equipment enclosure. In contrast, a short circuit covers a fault between two current carrying conductors, such as the hot (black) and neutral (white) wires.

Grounded Conductor - this is a current carrying conductor which is referenced to ground by bonding it to earth ground at the power source or main service panel. An example of a grounded conductor is the white wire provided in a power cable, which is sometimes called a neutral.

Grounding Electrode Conductor - this conductor is used to tie the equipment or system noncurrent-carrying metal parts to the earth grounding electrode.

Impedance - a combination of resistance and reactance. Whereas the resistance does not change with the current frequency, reactance (in the case of conductors) increases with increasing frequency.

Main Bonding Jumper - this is a conductor that is used to tie the power supply grounded conductor (neutral) to the supply enclosure, equipment grounding conductors, and earth grounding conductor.

Neutral Conductor - This conductor often is also the grounded conductor (with some exceptions) and is colored white or natural gray.

APPENDIX I

GROUNDING CHECKLIST

This checklist details the principal factors required for a durable and effective grounding/lightning protective system. Not all of the items require compliance, depending on the circumstances. Rather, the grounding/lightning protection system should be reviewed in light of this checklist to ensure that no particular area has been left unaddressed.

Preparation:

- Has consideration been given to the placement of equipment or shelters from an earth grounding perspective (local soil quality, etc.; see section 10)?
- Has consideration been given to how extensive the earth grounding electrode system should be (refer to section 12)?
- Has the soil condition been considered in selecting the type and quantity of earth grounding electrodes (refer to section 3.1)?

Earth Grounding Conductor:

- Is the grounding wire suitably sized and of a corrosion-resistant material?
- Are loops, kinks, and sharp bends avoided?
- Are grounding conductors routed horizontally or down toward the ground rod? (avoid going up and over objects)
- Are splices in the conductor avoided?
- Are the grounding wires free of heavy corrosion and damage, especially at the ends?

Bonding Points:

- Are ground wires not twisted around ground rods, masts, etc.?
- Are wires rigidly clamped (not twisted or solely taped)?
- Are clamps/bonding points adequately secured to avoid loosening with time?
- Are grounding/bonding connections free of paint or any signs of corrosion?
- Are dissimilar materials avoided at the bonding point?

Earth Grounding Electrode:

- Are ground rods or other electrodes suitably installed?
- Are ground rods or other electrodes free of paint?
- Is the use of aluminum for electrodes avoided?
- Where possible, are electrodes installed away from areas where outcroppings of rock are evident (signifying poor soil conditions)?
- Where soil is shallow, are ground rods/wires buried horizontally?
- If used, are grounding plates suitably sized?
- Where the SWGK is used, are the two jumper cables installed?

- Are electrodes installed where the ground will receive rain water or other source of moisture?
- Are grounding electrodes installed away from locations with normal pedestrian traffic or personnel tents?
- Are power and signal cables not laid across or near earth grounding conductors or cables?
- Where the earth grounding resistance is questionable (poor soil, buried plumbing that may be coated, etc.), has a test been conducted (Appendix E).
- Where soil quality is poor, are multiple grounding electrodes installed and interconnected?
- Where soil quality is poor, is conductivity enhanced through the use of salt?

Grounding/Bonding Dead Metal Objects/Structures:

- Are all electronics equipment shelters, generators, etc. properly earth grounded?
- Where used, are all CONEXes or other metal shelters normally occupied by personnel grounded (including observation towers, bathrooms, and kitchens)?
- Are all electronics equipment shelters, CONEXes, and other metal shelters located within 8 feet of each other bonded together?
- Are metal roofs which are provided to protect electronic equipment, generator, etc. properly grounded as well as bonded to nearby equipment?
- Are generators, water tanks, POL tanks, and other metal objects grounded as well as bonded to any other metal objects/structures within 8 feet?

Lightning Protective Masts (LPM):

- Is all equipment requiring protection located within the LPM cone of protection? (as much as is reasonably possible)
- Is the air terminal at top of the LPM durable?
- Is a suitable grounding conductor provided from the air terminal to ground?
- Is the LPM suitably grounded via a dedicated ground rod, or otherwise grounded to an existing ground rod system?
- If any separate grounding electrodes are located near the LPM grounding electrode, are they interconnected to the LPM grounding electrode?
- Are all bonding connections secure? (clamped, not taped or twisted)

Other:

- Are personnel informed to remain within appropriate shelters when possible during electrical storms (see Appendix F)?
- Are lightning protection masts and related grounding inspected following electrical storms to ensure that damage was not sustained?
- If tents are used to house personnel, are they located away from ground rods and antenna masts (tents provide poor protection; especially where personnel lie across the ground)?

RECOMMENDED CHANGES TO EQUIPMENT TECHNICAL PUBLICATIONS



SOMETHING WRONG WITH THIS PUBLICATION?

FROM: (PRINT YOUR UNIT'S COMPLETE ADDRESS)

DATE SENT

THEN...JOT DOWN THE DOPE ABOUT IT ON THIS FORM. CAREFULLY TEAR IT OUT. FOLD IT AND DROP IT IN THE MAIL.

PUBLICATION NUMBER				PUBLICATION DATE	PUBLICATION TITLE
--------------------	--	--	--	------------------	-------------------

BE EXACT PIN-POINT WHERE IT IS				IN THIS SPACE TELL WHAT IS WRONG AND WHAT SHOULD BE DONE ABOUT IT:
PAGE NO	PARA-GRAPH	FIGURE NO	TABLE NO	

PRINTED NAME GRADE OR TITLE AND TELEPHONE NUMBER	SIGN HERE
--	-----------

FILL IN YOUR
UNIT'S ADDRESS

FOLD BACK

DEPARTMENT OF THE ARMY

OFFICIAL BUSINESS

BUSINESS REPLY MAIL

FIRST CLASS MAIL PERMIT NO. 144 RED BANK NJ

POSTAGE WILL BE PAID BY

U.S. Army CECOM DSRM
ATTN: AMSEL-SF-SEP, bldg 2539
Ft. Monmouth, NJ 07703-5024

NO POSTAGE
NECESSARY
IF MAILED
IN THE
UNITED STATES

TEAR ALONG PERFORATED LINE



FOLD BACK