

**SUBCOURSE
OD1725**

**EDITION
B**

BASIC SCHEMATIC INTERPRETATION

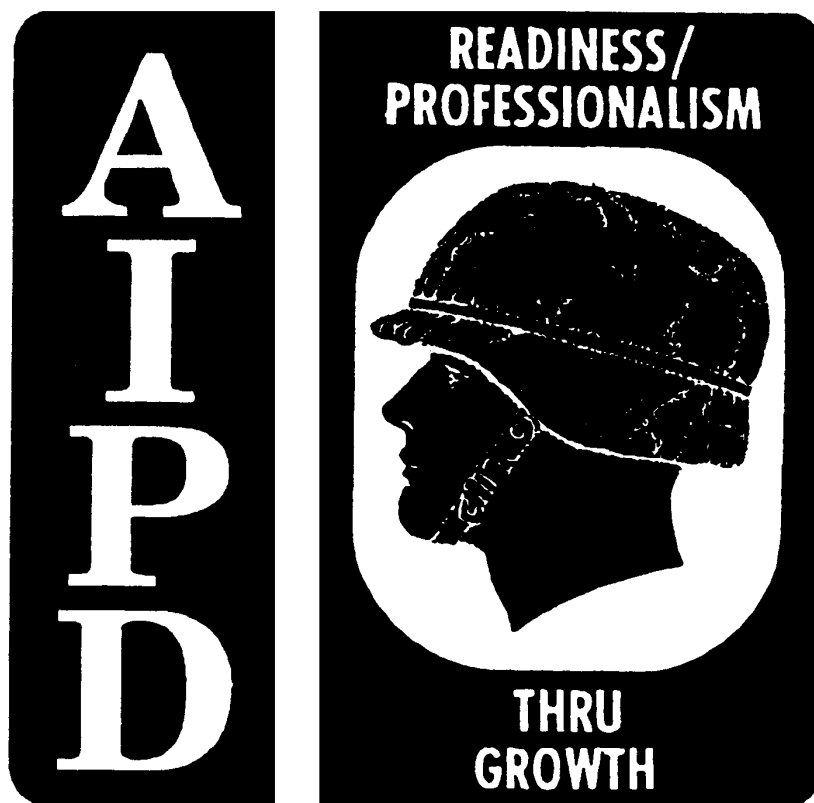

**THE ARMY INSTITUTE FOR PROFESSIONAL DEVELOPMENT
ARMY CORRESPONDENCE COURSE PROGRAM**

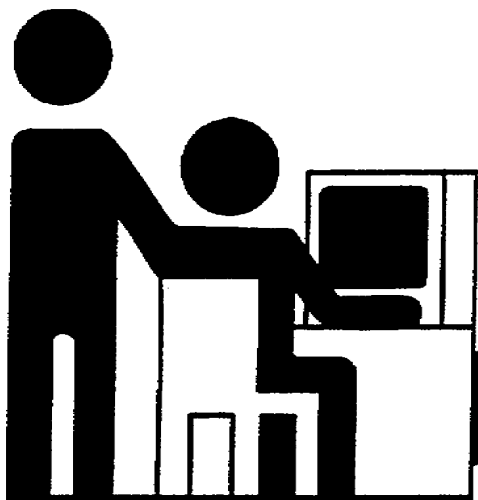

Notice to Students

Use the Ordnance Training Division website,
<http://www.cascom.army.mil/ordnance/>,
to submit your questions, comments, and suggestions
regarding Ordnance and Missile & Munitions
subcourse content.

If you have access to a computer with Internet capability and can receive e-mail, we recommend that you use this means to communicate with our subject matter experts. Even if you're not able to receive e-mail, we encourage you to submit content inquiries electronically. Simply include a commercial or DSN phone number and/or address on the form provided. Also, be sure to check the Frequently Asked Questions file at the site before posting your inquiry.

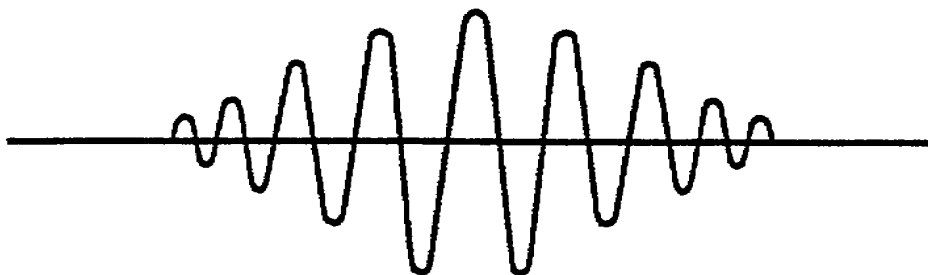

BASIC SCHEMATIC INTERPRETATION

Subcourse Number OD1725

Edition B
March 1996

United States Army Ordnance Center and School

5 Credit Hours

SUBCOURSE OVERVIEW

This subcourse presents basic schematic interpretation in three parts. Part A identifies basic symbols used in circuit schematics. Part B discusses typical component characteristics and their functional use within a circuit. Part C describes the methods to determine reference designators and the procedures for wire tracing in a circuit. Part C also includes a wire tracing exercise.

Terminal Learning Objective

Actions: You will recognize the various symbols used in schematic diagrams of Army technical manuals. You will understand their characteristics and how they function in typical circuit applications. You will also perform wire tracing in a practical wire tracing exercise using extracts from an Army technical manual.

Conditions: You will be given the subcourse booklet with extracts from TM 9-5855-267-24.

Standards: You will perform wire tracing procedures in accordance with TM 9-5855-267-24.

There are no prerequisites for this subcourse.

The following publications are the references for this subcourse:

FM 11-60	Basic Principles, Direct Current, November 1982.
FM 11-61	Basic Principles, Alternating Current, November 1982.

FM 11-62	Solid State Devices and Solid State Power Supplies, September 1983.
FM 11-72	Digital Computers, September 1977.
TM 9-5855-267-24	Sight, Tank Thermal AN/VSG-2, December 1980.
ANSI Y32.2	Graphic Symbols for Electrical and Electronics Diagrams, October 1975.

This subcourse contains information which was current at the time it was prepared. In your own work situation, always refer to the latest publications.

The words "he," "him," "his," and "men," when used in this publication, represent both the masculine and feminine genders unless otherwise stated.

TABLE OF CONTENTS

<u>Section</u>	<u>Page</u>
Subcourse Overview	i
Lesson: Basic Schematic Interpretation	1
Part A: Identification of Electrical and Electronic Schematic Symbols	2
Part B: Component Characteristics and Functional Use	22
Part C: Wire Tracing	30
Practice Exercise	36
Answer Key and Feedback	38
Appendix A: List of Acronyms and Abbreviations	49
Appendix B: List of Designation Letters	51
Appendix C: Extracts from TM 9-5855-267-24	53

CONTINUE TO THE NEXT PAGE.

LESSON

BASIC SCHEMATIC INTERPRETATION

LEARNING OBJECTIVE

- Actions:
- a. Identify the symbols used in typical schematic diagrams of Army technical manuals.
 - b. Describe the characteristics and circuit functions of electrical and electronic components used in Army fire control instruments.
 - c. Wire trace a circuit using the procedures specified in an Army technical manual.
- Conditions: You will be given the subcourse booklet with extracts from TM 9-5855-267-24.
- Standards: You will perform the wire tracing procedures in accordance with TM 9-5855-267-24.

INTRODUCTION

One of the essential elements of an effective unit is the ability to effectively repair malfunctioning equipment and return it to service quickly. For the fire control systems repairer (MOS 45G), this often means the adjustment, replacement, or repair of the electrical and electronic components within the fire control instruments and their associated test equipment. In order for the technician to understand the operation of the equipment and the procedures for troubleshooting and repair, he must be able to identify components and understand how they function within that particular circuit. He must also be able to trace signals through and between circuits.

This lesson identifies typical symbols used in Army technical manuals for electrical and electronic systems. It describes their functional operation in circuit application. It also provides an exercise in wire tracing, using the procedures specified by TM 9-5855-267-24.

PART A - IDENTIFICATION OF
ELECTRICAL AND ELECTRONIC SCHEMATIC SYMBOLS

In order to understand the functioning of an electrical or electronic circuit, you must be able to "read" the schematic diagram of that circuit. A schematic diagram is the road map of the circuit. In order to get from one point to another, you must be able to follow the appropriate route and understand the meanings of the various symbols found along the way.

1. Symbols. Just as the road map uses symbols to represent the highways, cities, interchanges, and other elements displayed, the schematic diagram uses symbols to represent the components used to make up a circuit. Symbols are used to indicate conductors, resistors, switches, motors, transistors, and other electrical and electronic parts. Components in a circuit schematic are generally represented by such a symbol and/or a letter designator. This part of the lesson reviews many of the symbols used by Army technical manuals in the schematic diagrams of the appropriate equipment.

2. Conductors. Basic to any schematic diagram is the use of straight lines to indicate conductors. The conductor is the "roadway" of the circuit map. The conductors interconnect the components of the circuit. Conductors often cross paths with one another in the circuit. This may occur with or without their making electrical contact. Figure 1-1 illustrates the typical methods for crossing conductors within a schematic diagram.

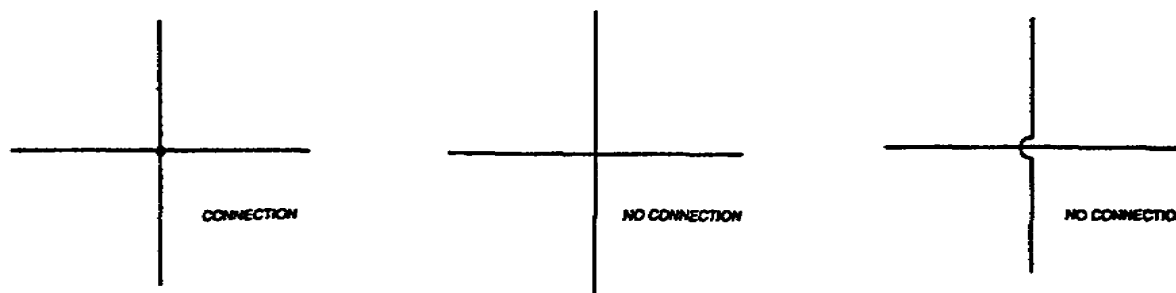

Figure 1-1. Crossing Conductors.

There are many types of conductors used in electrical and electronic circuits. They may range from the thin layers of metal foil used in printed-circuit boards to heavy cables used in power transmission. Cables generally consist of two or more conductors, usually in the same insulation jacket. A special type of conductor found in many electronic applications is the shielded wire or coaxial cable. Here, the conductor is

surrounded by a metallic shield to protect against interference from adjacent electrical influence. The shielding on the cable may or may not be grounded. Figure 1-2 shows some common symbols for shielded conductors.

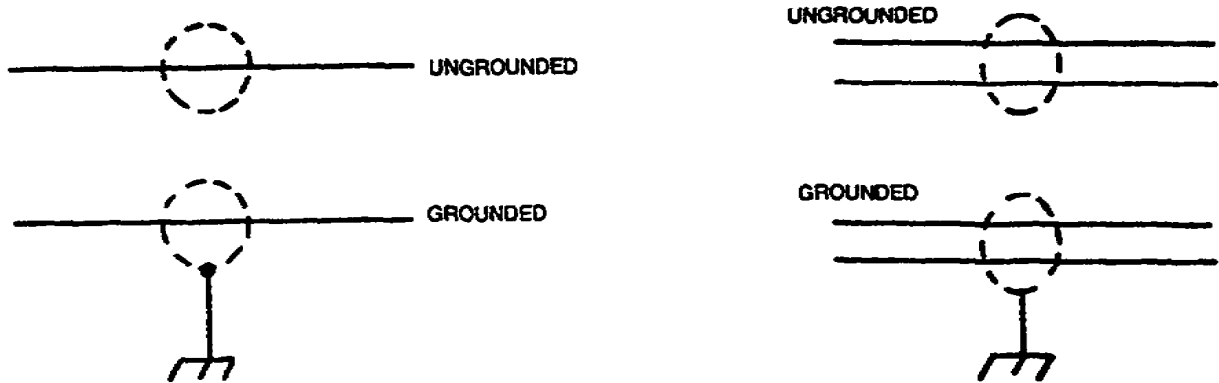

Figure 1-2. Shielded Conductors.

3. Basic Components. There are literally hundreds of different types of electrical and electronic components in use today. However, three components are widely used in a wide variety of applications. These three components are found in most circuit schematics of any complexity. The three components are (a) resistors; (b) capacitors; and (c) inductors.

a. Resistors. Resistors are unquestionably the most commonly used circuit components. They are found in almost every electrical and electronic schematic diagram. Resistors are appropriately named in that they are designed to "resist" the flow of electrical current. Resistors are typically shown in schematics by the symbol illustrated in figure 1-3.

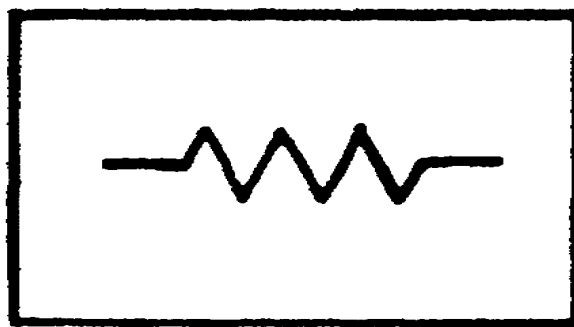

Figure 1-3. Fixed Resistors.

In addition to the symbol, the resistor is generally labeled by the letter "R" followed by a number, e.g., R1, R2, etc. The resistance value, measured in ohms, may also be indicated. If the resistance is not indicated, you can determine it by

observing the color coding used on most resistors. Figure 1-4 lists the color-coded values used in marking carbon resistors.

COLOR	SIGNIFICANT FIGURE	DECIMAL MULTIPLIER	RESISTANCE TOLERANCE	RELIABILITY LEVEL PER 1000 HRS.
BLACK	0	1	PERCENT ±	
BROWN	1	10	---	1%
RED	2	100	---	.1%
ORANGE	3	1,000	---	.01%
YELLOW	4	10,000	---	.001%
GREEN	5	100,000	---	
BLUE	6	1,000,000	---	
VIOLET	7	10,000,000	---	
GRAY	8	100,000,000	---	
WHITE	9	1,000,000,000	---	
GOLD	---	.1	5	
SILVER	---	.01	10	
NO COLOR	---		20	

Figure 1-4. Color Code for Resistors.

Several variations of resistors exist. The symbol shown in figure 1-3 is that of a fixed resistor, one of a set or fixed value. Resistors also may have variable values of resistance. This may be achieved by the use of variable resistors that may be adjusted, or through the use of tapped resistors which have two or more selected values of resistance. Figure 1-5 shows the symbols commonly used to indicate variable and tapped resistors in schematic diagrams.

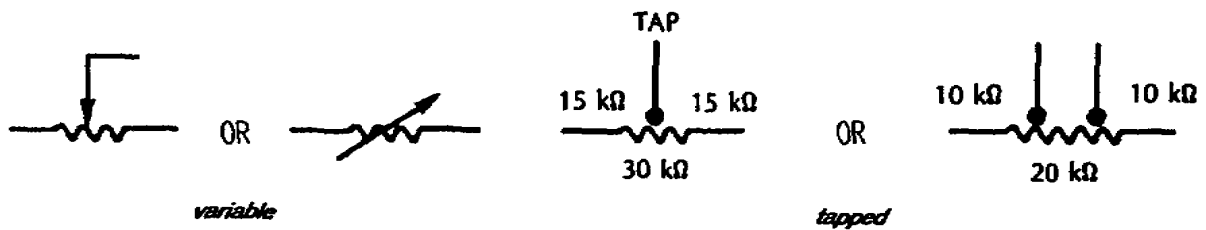

Figure 1-5. Variable and Tapped Resistors.

b. Capacitors. Next to resistors, capacitors are the most common components found in schematic diagrams. Capacitors are capable of storing electrical charges. They have the ability to block direct current (DC) while passing alternating current (AC). The standard symbols used to represent fixed capacitors are shown in figure 1-6. In addition to the symbol, a capacitor is generally labeled with the letter "C." The value of the capacitor may also be indicated. The basic unit of capacitance

is the farad; but most practical capacitors will be rated in microfarads (MF) or picofarads (PF). As with resistors, if the value is not given, determine it by observing the color coding found on many types of capacitors. Figure 1-7 is a table indicating the use of color coding for some capacitors.

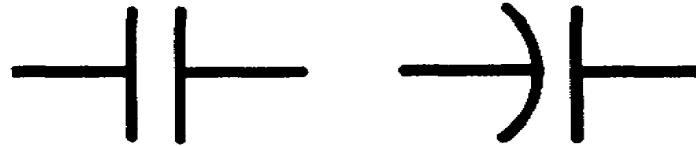

Figure 1-6. Fixed Capacitors.

COLOR	CAPACITANCE			TOLERANCE (PERCENT)	VOLTAGE RATING	
	1ST DIGIT	2ND DIGIT	MULTIPLIER		1ST DIGIT	2ND DIGIT
BLACK	0	0	1	±20	0	0
BROWN	1	1	10		1	1
RED	2	2	100		2	2
ORANGE	3	3	1,000	±30	3	3
YELLOW	4	4	10,000	±40	4	4
GREEN	5	5	100,000	±5	5	5
BLUE	6	6	1,000,000		6	6
VIOLET	7	7			7	7
GRAY	8	8			8	8
WHITE	9	9		±10	9	9

Figure 1-7. Six-Band Color Code for Capacitors.

Capacitors also come in many variations. In addition to fixed capacitors, you may often find variable, ganged variable, or electrolytic (polarized) capacitors. Figure 1-8 illustrates the symbols used for some variations of capacitors.

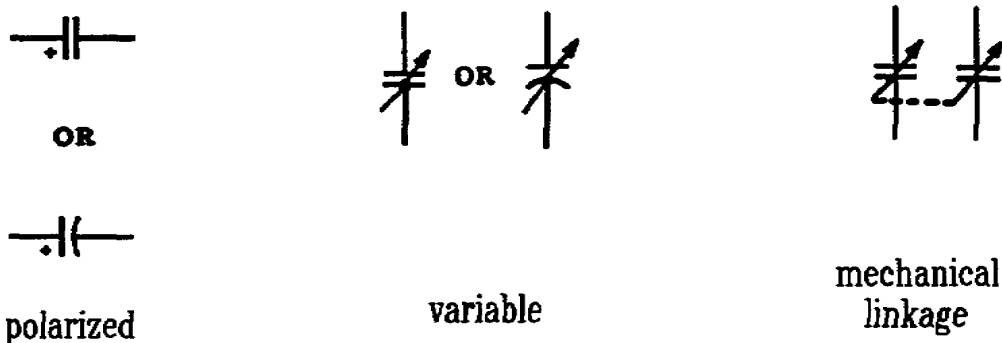

Figure 1-8. Special Purpose Capacitors.

c. Inductors. While not used as extensively as resistors and capacitors, inductors (or coils) are still a common basic component of many electrical and electronic circuits. An inductor has the property of opposing a change in the existing current. The standard symbol for an inductor is shown in figure 1-9. Inductors are generally labeled with the letter "L" and are rated in henrys, the basic unit of inductance. In most practical applications, the actual rating will be given in millihenrys or microhenrys.



Figure 1-9. Air Core Inductor.

Inductors, like the other basic components, come in a variety of configurations. They may be variable, tapped, aircore, iron core, etc. Figure 1-10 illustrates the symbols used for some variations of inductors.

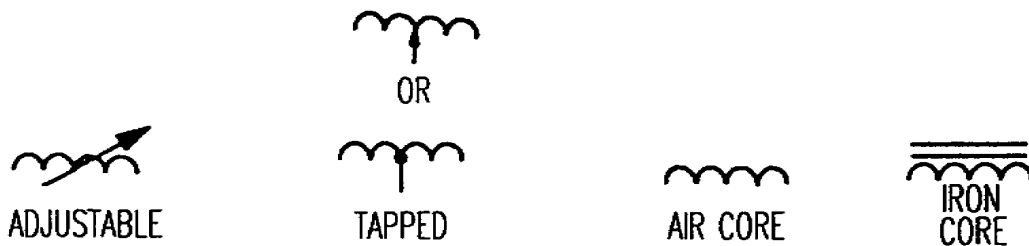

Figure 1-10. Special Purpose Inductors.

4. Power Sources. Every electrical circuit must have a source of electrical power. Some electrical and/or electronic devices have an internal power source, but most rely on some external source to supply the power necessary to operate them.

When the power source is external to the particular schematic diagram being examined, generally only the connectors bringing in the power are identified and labeled with the appropriate originating source. However, when the source of the power for a given circuit is internal to the schematic, it must be identified and represented by the appropriate schematic symbol.

Most electrical and electronic equipment is operated by "plugging" it into an external power source, or by some installed power source (usually a battery). As previously stated, external power sources are usually identified on a schematic diagram by their point of entry into the circuit.

Internal power sources must be presented as an integral component of the circuit, and are represented graphically by the appropriate symbol. Some typical power sources are discussed below.

a. Batteries. Most of us use equipment powered by batteries in our every day life. Batteries are used to power such everyday equipment as flashlights, watches, radios, and to start our cars. They may be small enough to fit inside a watch, or large enough to propel a submarine through the water. They may be dry cells, such as used in a flashlight, or wet cells, such as those found under the hood of your automobile. They may be primary batteries or secondary batteries. Primary batteries have a fixed supply of energy and must be replaced when that supply is dissipated. Secondary batteries may be recharged when their energy supply runs low.

Regardless of the type or size of the battery, the schematic symbolism is the same. Figure 1-11 illustrates the symbols used to represent batteries in schematic diagramming. In schematics, the key to interpreting batteries is the manner in which they are connected. Figure 1-11A shows a single cell battery. Most often, the polarity of the battery is labeled in the schematic by a (+) and a (-) at the appropriate pole of the battery. In the absence of this labeling, the general rule is that the long line pole is the positive side and the short line pole is the negative. Figure 1-11B shows a multicell battery. The symbol does not necessarily represent the exact number of cells in the battery.

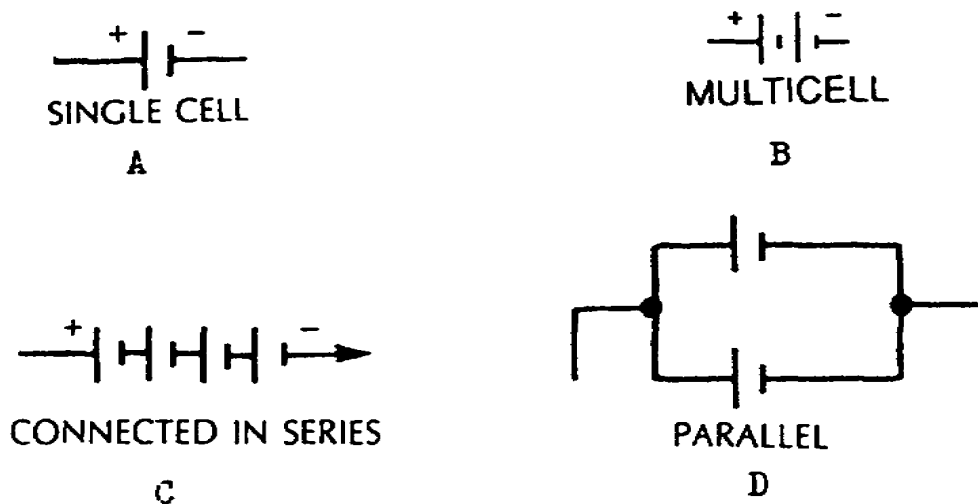

Figure 1-11. Battery Symbols.

In order to increase the voltage output of a battery power source, batteries are often connected in series. Figure 1-11C shows a series connected battery power source. In a series

connected battery source, the voltage output of the individual batteries is additive. Sometimes series connected batteries are illustrated the same way as multicell batteries. If the battery has the proper voltage rating, but lacks sufficient power for the given circuit, batteries may be parallel connected. Figure 1-11D shows a parallel connected battery power source. The output voltage of the battery power source is generally indicated on the schematic diagram.

b. Generators. Another common source of power for electrically powered equipment is the generator. Simply put, generators convert mechanical energy to electrical energy. Depending on the design and construction of the generator, the output may be set to meet the needs of the equipment supplied. Generators may be designed to provide either AC or DC power. AC generators are often referred to as alternators. Figure 1-12 shows the standard symbols used to represent generators or alternators in schematics.

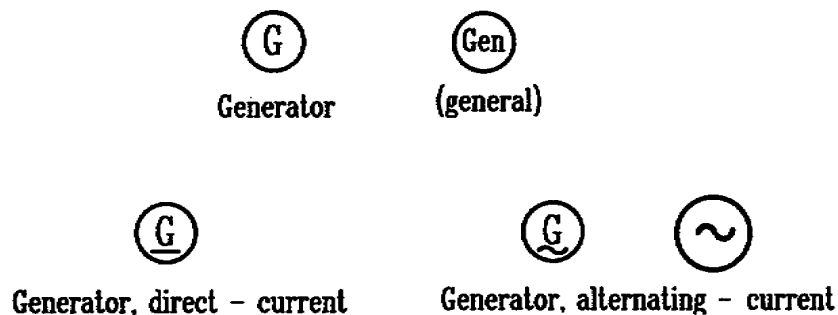

Figure 1-12. Generators.

c. Transformers. Although transformers are not a true power source, they are often the source of the voltages used in a given circuit. Typically, an external power source is applied to a transformer, which converts the input power to the voltage(s) necessary to operate the circuit supplied. Transformers are a special application of inductors, thus the similarity in the schematic symbol used. Figure 1-13 illustrates several types of transformers used in a variety of circuits.

Basically, transformers are two inductors placed in close physical proximity. The external input AC voltage is applied to the first inductor (the primary). The resulting electrical field will be "induced" onto the secondary inductor (the secondary), thus transferring the power from the primary to the secondary. The voltage and current produced in the secondary will be a factor of the relationship of the windings in the primary and the secondary. Transformers may be used to step-up

voltages, step-down voltages, or both. Disregarding the inherent losses in transformer action, the following rules apply:

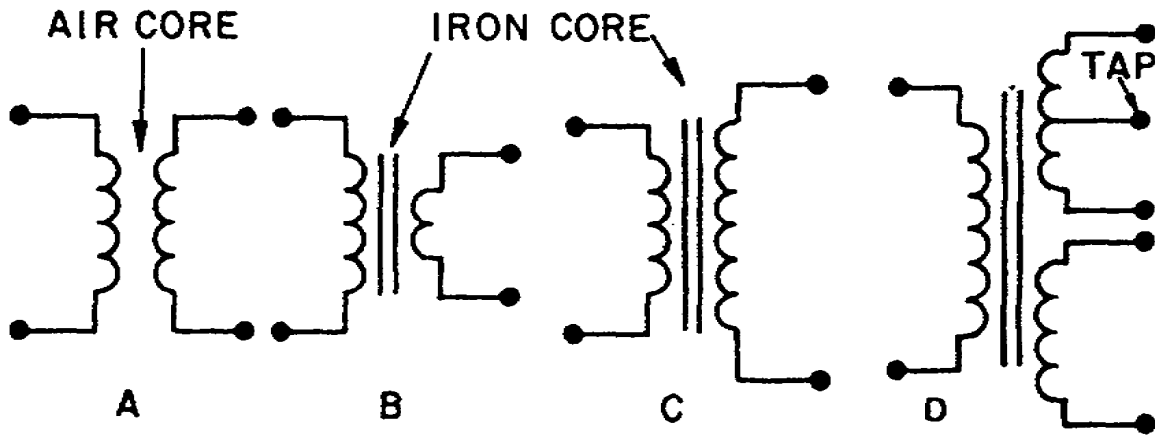

Figure 1-13. Transformers.

(1) If the number of windings in the primary and secondary is the same, the voltage and the current in the secondary will be the same as in the primary. Figure 1-13A illustrates a 1:1 ratio transformer.

(2) If the number of windings in the primary is greater than in the secondary, the voltage will be less in the secondary and the current will be greater. For example, if the number of windings in the primary is twice that of the secondary, the voltage in the secondary would be half that of the primary, and the current would be double that of the primary. Such a transformer is referred to as a step-down transformer. Figure 1-13B shows the symbol for a step-down transformer.

(3) If the number of windings in the primary is less than in the secondary, the voltage in the secondary is greater than in the primary, and the current will be less. For example, if the number of windings in the secondary are three times that of the primary, the voltage in the secondary will be three times that of the primary, and the current will be one-third. Such a transformer is referred to as a step-up transformer. Figure 1-13C shows the symbol for a step-up transformer.

Transformers have many configurations to meet the needs of the circuits they supply. Just as with inductors, transformers may have an air core, a fixed iron core, or an adjustable iron core. The output may be varied by adjusting the primary, the secondary, or the core. The secondary may be tapped to provide a variety of outputs in the secondary, or the transformer may have more than one secondary to provide separate outputs (see

figure 1-13D). In addition to the symbol, transformers are generally labeled by the letter "T."

d. Power Supplies. Like transformers, power supplies are not a true power source. They generally take an input from an external, power source and convert that source to usable voltages to operate the circuits they supply. Typically, a power supply will convert an AC input into one or more DC outputs. Most power supplies consist of four basic sections: a transformer; a rectifier; a filter; and a regulator. Figure 1-14 shows a simple block diagram of a power supply and the effects of the basic components.

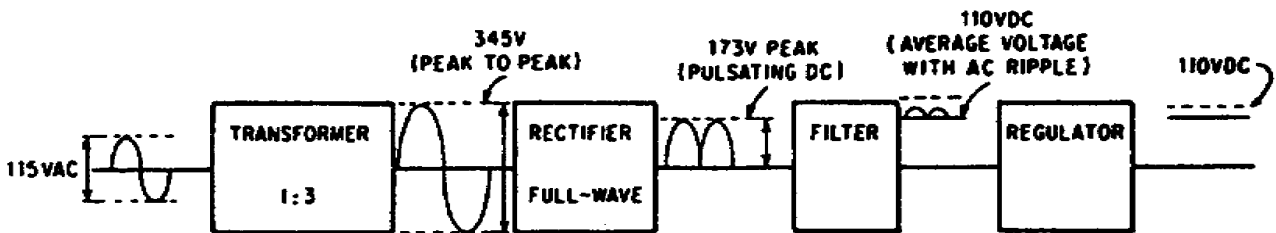

Figure 1-14. Basic Power Supply.

Power supplies may be designed to produce one or several different output voltages. Depending on the complexity of the circuit demand, power supplies may be fairly simple or they may be quite extensive. Often the power supply for a circuit will require a separate schematic diagram to illustrate the components and functional operation of the power supply. Figure 1-15 illustrates a schematic of a simple power supply. Power supplies are labeled with the letters "PS."

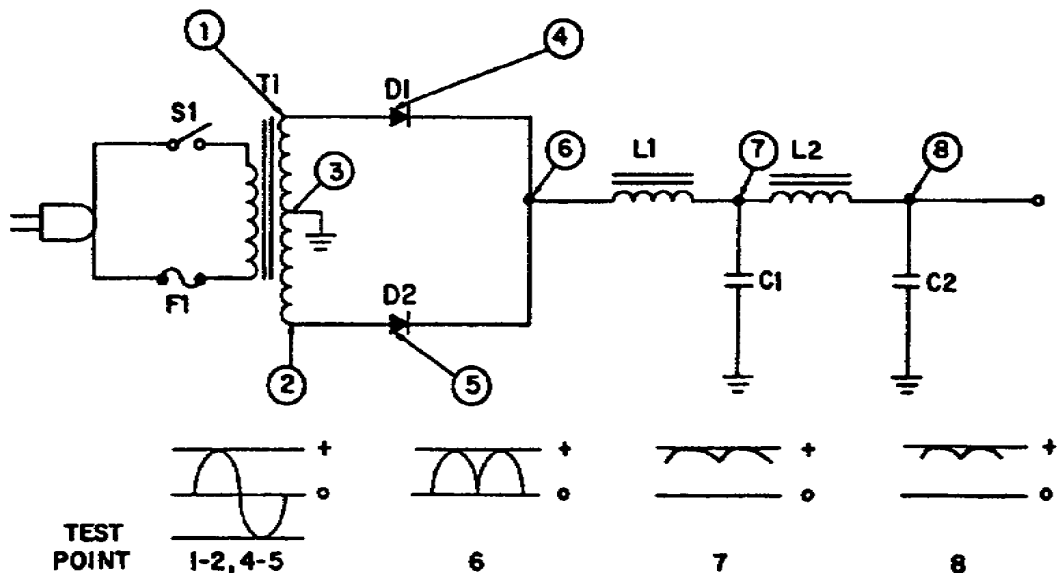

Figure 1-15. Simple Power Supply (Schematic).

5. Controls. Many electrical and electronic circuits include controls and indicators to assist the operator in the use and repair of the equipment. These controls may consist of devices such as switches, relays, fuses, plugs and jacks, test points, and indicators. These operator aids are normally represented in the circuit schematic diagram to illustrate their effect on the circuit operation.

a. Switches. Switches give the operator control over the operation of the equipment. By positioning the switch, the operator directs the operation of the circuit by routing the direction of electrical signals within the circuit. Switches may be simple, such as an on/off switch, or they may be complex, being of multiposition/multifunction design. They may be designed to be momentary action, to latch in a given position, make-before-break, or to perform any number of specific functions. While the possible designs for switches are almost limitless, figure 1-16 illustrates several commonly used switch symbols. In addition to the symbol, switches are normally labeled with the letter "S." A special type of switch is the circuit breaker. Circuit breakers normally act as on/off switches as well as providing overvoltage/overcurrent protection to the circuit. The symbol for a typical circuit breaker is shown in figure 1-16. Circuit breakers are labeled with the letters "CB."

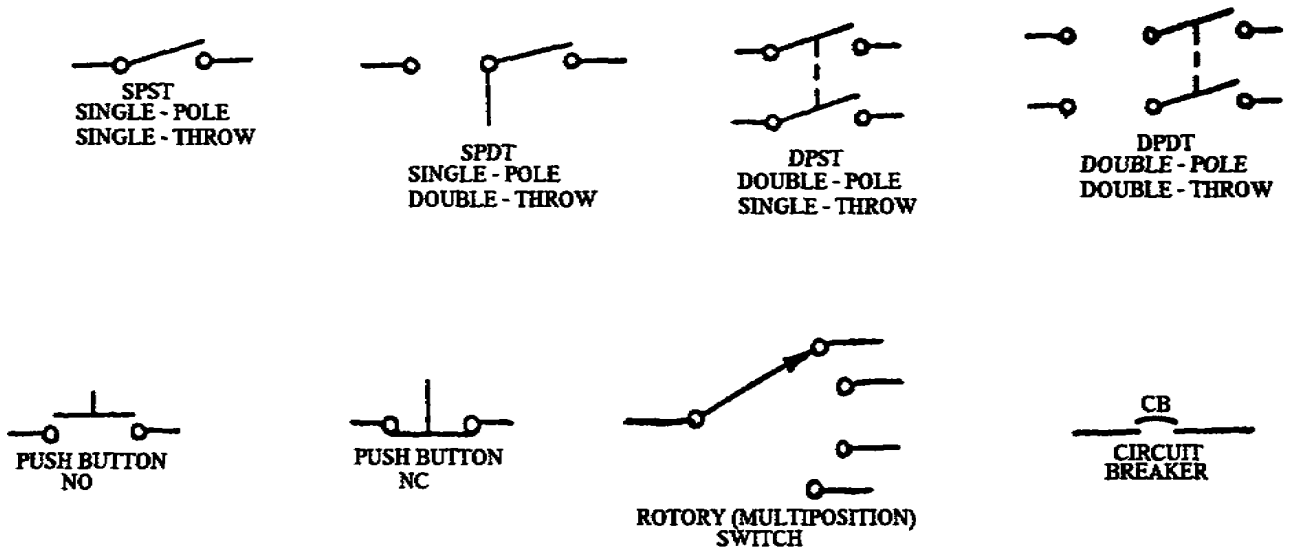

Figure 1-16. Switches.

b. Relays. The previous description of switches stated that switches direct the routing of electrical signals within a circuit. A relay functions similarly. Rather than being controlled manually by the operator, a relay is operated electrically by energizing a coil to realign the contacts of the

relay and re-route the electrical signals. Relays may be indicated in schematics only by their coil and its energizing source, only by the contacts used by the particular circuit, or by both. Contacts are normally shown in the position with the relay de-energized, unless otherwise indicated. Figure 1-17 illustrates some methods of representing relays symbolically. Relays are labeled with the letter "K."

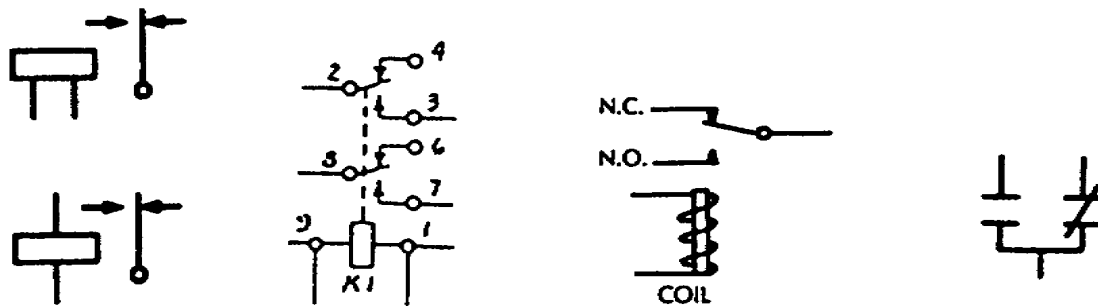

Figure 1-17. Relays.

c. Fuses. Fuses are used to protect circuits from overvoltage or overcurrent conditions. Unlike circuit breakers, which are electromechanical, fuses are thermally sensitive. When the circuit becomes overloaded, the metal alloy of the fuse melts (opens) and removes the power source from the equipment. Fuses are designed to meet the requirements of the circuits they are protecting. The symbols used for fuses are shown in figure 1-18. Fuses are labeled with the letter "F."



Figure 1-18. Fuses.

d. Plugs, Jacks, and Test Points. Plugs and jacks are generally used to connect the equipment to some external device, or to interconnect circuits and components within the equipment. Plugs and jacks may be single conductor or multiconductor. They may be permanent or removable, shielded or unshielded. Jacks and plugs often provide a convenient means to check or test critical signals. This provides an extremely useful function in troubleshooting. Where it is impossible or impractical to check a signal at a jack or plug, circuits are often designed to provide test points. These test points may be internal to the circuit or tapped off and provided at an external point. Figure 1-19 illustrates some typical symbols used for jacks, plugs, and test points. Jacks are labeled with the letter "J"; plugs with the letter "P"; and test points with the letters "TP." With

multiconductor plugs and jacks, the individual conductors are generally identified by pin or pin socket numbers.

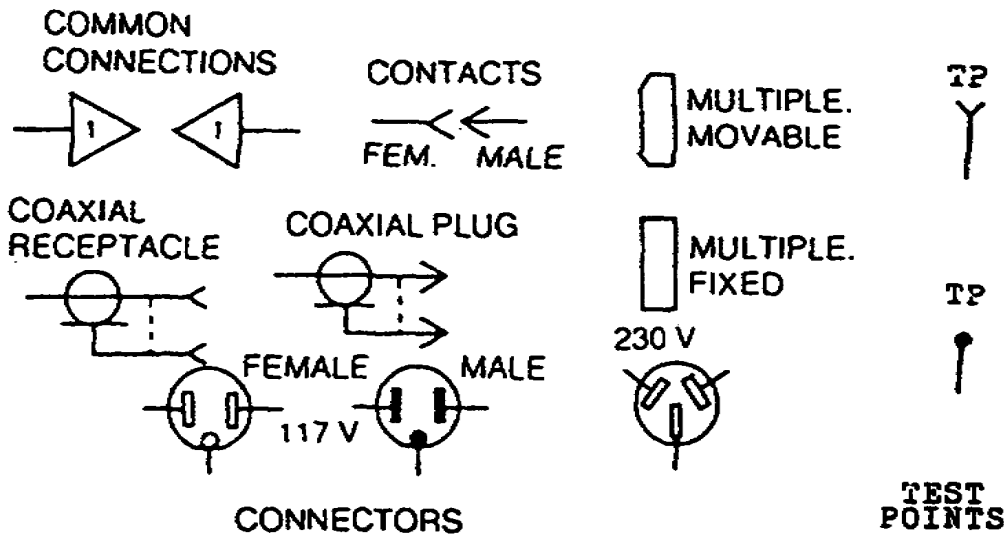

Figure 1-19. Test Connections.

e. Indicators. Indicators are generally placed in electrical or electronic circuits to provide the operator a status of some function of the equipment. The indicator may be audible, visual, or both.

(1) Audible indicators may consist of a horn, buzzer, speaker, or other noise producing device. Most often these devices are used as alarms or warnings. Figure 1-20 shows the symbols for some types of audible indicators. Audible indicators are labeled with the letters "LS."

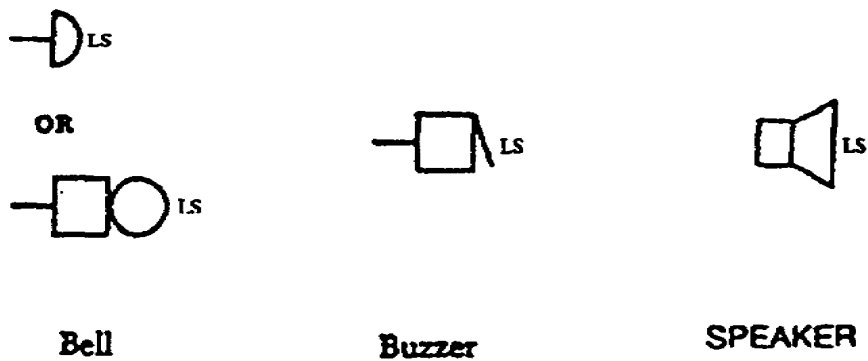

Figure 1-20. Audible Indicators.

(2) Visual indicators are typically some type of a light, dial, or meter. Visual indicators may provide a warning or present some type of status. Dials and meters are most often represented by the symbol shown in figure 1-21 with its accompanying legend.

A wide variety of light indicators are also used to provide important information to the operator. These may include such items as indicator lamps with various color lenses such as a power on indicator, a flashing neon bulb such as a high temperature alarm, a digital display such as a range readout, or a graphic display such as a screen on an oscilloscope. The light indicator may be provided by such sources as lamps, fluorescent or neon tubes, or light-emitting solid-state devices. Generally, light indicators or displays are shown on schematics by one of the symbols illustrated in figure 1-22 and are labeled with the letters "DS."











			INSERT APPROPRIATE DESIGNATIONS		
A	Ammeter 	DTR	Demand-totalizing relay	RF	Reactive factor meter
AH	Ampere-hour meter	F	Frequency meter 	SY	Synchroscope
C	Coulombmeter	GD	Ground detector	t'	Temperature meter
CMA	Contact-making (or breaking) ammeter	I	Integrating meter	THC	Thermal converter
CMC	Contact-making (or breaking) clock	INT	Integrating meter	TLM	Telemeter
CMV	Contact-making (or breaking) voltmeter	μA or UA	Microammeter	TT	Total time meter
CRO	Oscilloscope 	MA	Milliammeter	V	Voltmeter 
DB	DB (decibel) meter	NM	Noise meter	VA	Volt-ammeter
	Audio level/meter 	OHM	Ohmmeter 	VAR	Varmeter 
DBM	DBM (decibels referred to 1 milliwatt) meter	OP	Oil pressure meter	VARH	Varhour meter
DM	Demand meter	OSCC	Oscillograph, string	VI	Volume indicator
		PF	Power factor meter	VU	Standard volume indicator
		PH	Phasemeter 		Audio-level meter 
		PI	Position indicator	W	Wattmeter 
		RD	Recording demand meter	WH	Watt-hour meter

Figure 1-21. Readout Devices.



Figure 1-22. Light Indicators.

An exception is often made when the light source is a light-emitting diode (LED) or a liquid-crystal display (LCD). These solid-state devices may be represented symbolically as above, or they may be represented by the symbols shown in figure 1-23 and labeled with the letters "CR."

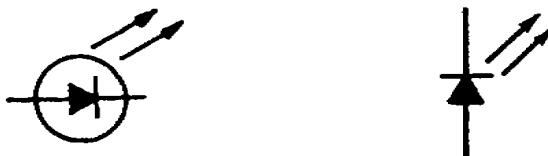

Figure 1-23. Solid-State Light Indicators.

6. Vacuum Tubes. While vacuum tubes are not used to the extent that they were in the past, you may still encounter electronic circuits that use these devices. As with electronic components, vacuum tubes come in a variety of configurations. They may range from a simple two element diode to a multielement cathode-ray tube.

Each type of vacuum tube has a symbol to represent it in a circuit schematic. Vacuum tubes are indicated by a circle representing the envelope of the tube, with the elements of the device shown within. Figure 1-24 illustrates a triode vacuum tube. As shown, the element labeled 1 is the cathode heater. Element 2 is the cathode. (Sometimes a directly heated cathode will be represented by the symbol of the cathode heater alone.) The element labeled 3 is the plate or anode. Element number 4 is the control grid. Additional elements may be added depending on the circuit function of the vacuum tube. Figure 1-25 shows several symbols for various designs of vacuum tubes.

The general operating principle of a vacuum tube is control of the current flow through the tube. This is done by heating the cathode, directly or indirectly, and applying a bias voltage between the cathode and the plate. The amount of current that flows through the tube is controlled by adjusting the bias or through the use of a variety of grids. Figure 1-26 shows the triode shown in figure 1-24 hooked up in a circuit to provide voltage amplification. Vacuum tubes are labeled with the letter "V. "

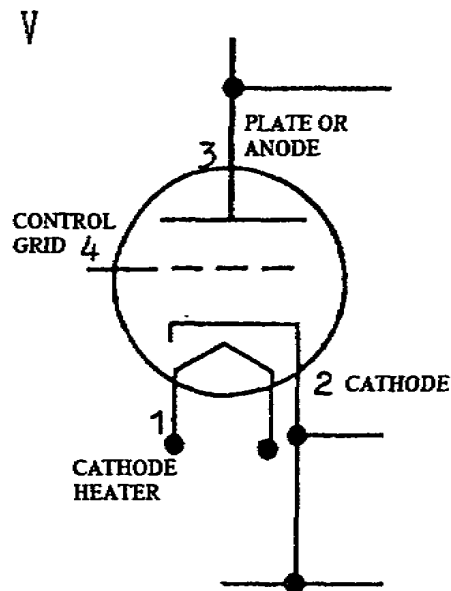

Figure 1-24. Triode Vacuum Tube.

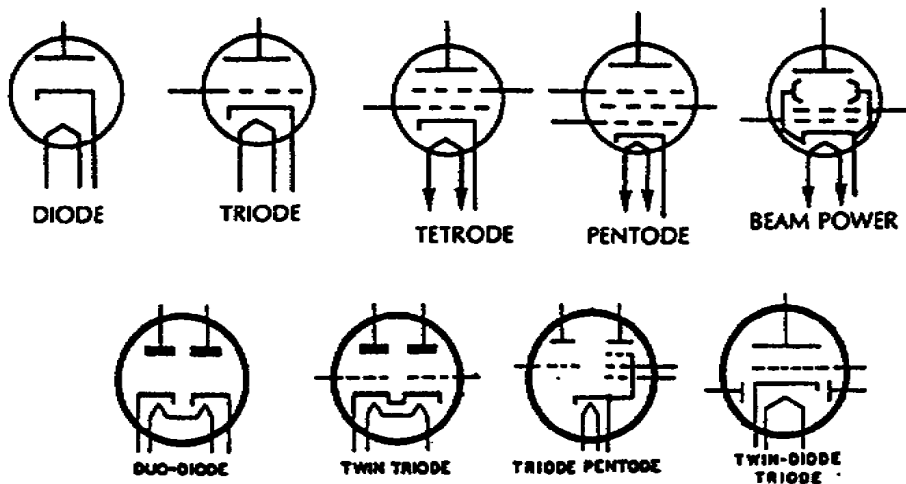

Figure 1-25. Vacuum Tubes.

A special type of vacuum tube is the cathode-ray tube (CRT). Unlike the other types of vacuum tubes, CRTs are still widely used. They are the element known as the "picture tube" in your television set. They are used as the "screen" on radar displays and oscilloscopes. CRTs have one feature that cannot be accomplished with the use of other type tubes or transistors; they can convert electrical signals to visual display. Figure 1-27 shows the symbol for a CRT.

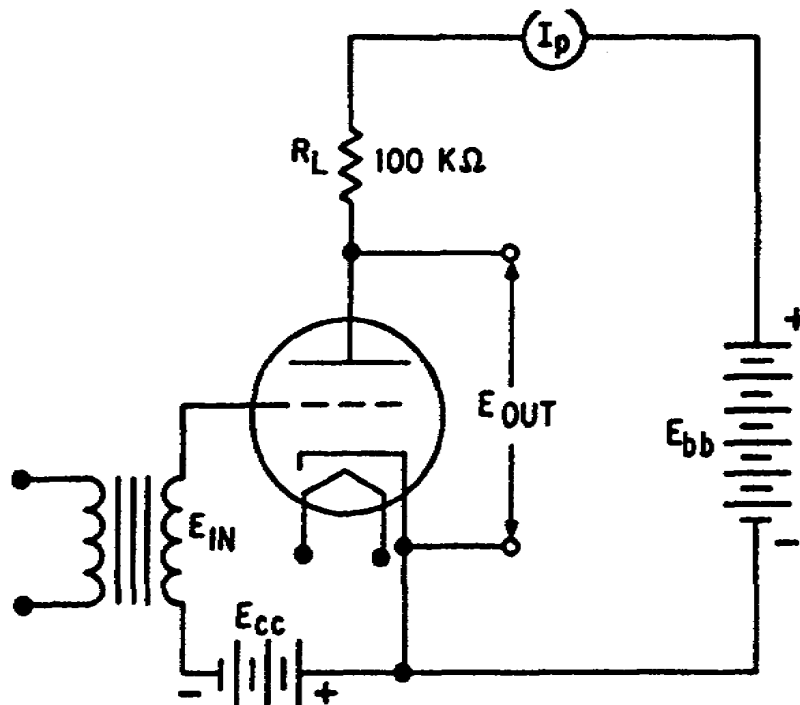

Figure 1-26. Triode Amplifier.

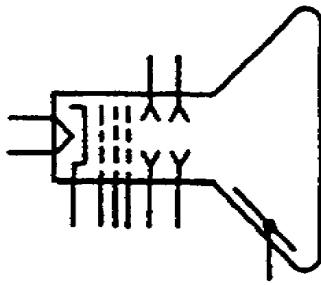

Figure 1-27. Cathode-Ray Tube (CRT)

7. Solid-State Devices. Solid-state devices (sometimes referred to as semiconductors) have, to a large extent, replaced vacuum tubes in the design of most modern electronic equipment. Solid-state devices are generally made of silicon or germanium that is "doped" with impurities to provide the desired conductivity. They may be doped to produce either p-type material (positive) or n-type material (negative). These semiconductors are used in the place of vacuum tubes due to these advantages: they are smaller, take less power to operate, usually cost less, and are more rugged.

a. Transistors. Probably the most common of these solid-state devices is the transistor. While there are numerous variations, most transistors are either pnp transistors or npn transistors. Figure 1-28 shows the symbol for a npn and a pnp transistor. The key to recognizing a npn or pnp is the direction of the arrow on the emitter. On the pnp transistor symbol, the arrow points inward; on the npn, the arrow points outward. The elements of the transistor operate much like the elements of the vacuum tube. The emitter functions much as the cathode; the collector as the plate; and the base much like the grids. Transistors are labeled with the letter "Q."

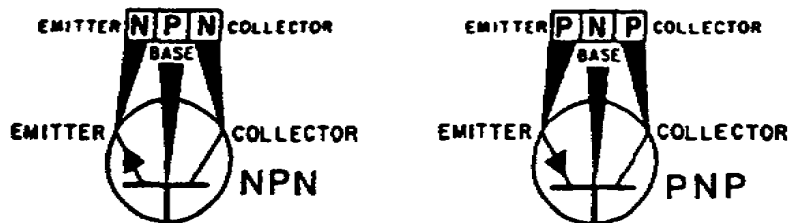

Figure 1-28. NPN, PNP Transistors.

b. Diodes. Another common solid-state component is the diode. A diode consists of one piece of p-type material and one piece of n-type material formed together to create a p-n junction. This p-n junction has the property to pass current in only one direction. Diodes are also designed in a number of

variations to meet special applications. Figure 1-29 shows the schematic symbol for some commonly used diode applications. Diodes are generally labeled with the letter "D" or the letters "CR." Exceptions are the symbol for the zener diode, which is often labeled "VR", and the light-emitting diode (LED), which may be labeled "DS."

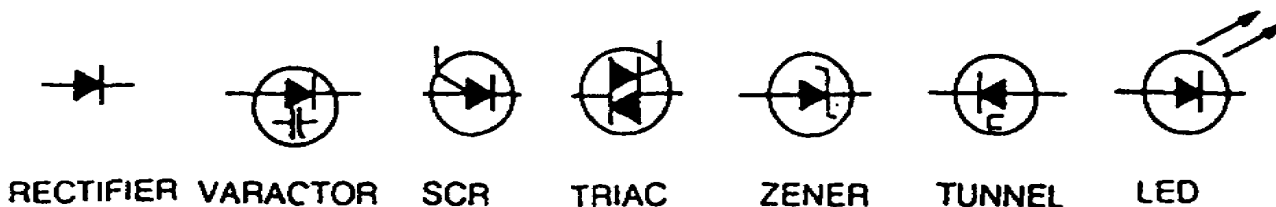

Figure 1-29. Diodes.

c. Special Purpose Devices. As indicated above, transistors and diodes may be constructed in a variety of designs to meet the needs of special applications. While it would be impractical to attempt to list them all, some of the more common special purpose solid-state symbols are shown in figure 1-30. The symbols shown are as follows:

- (1) Silicon-controlled rectifier (SCR).
- (2) Silicon-controlled switch (SCS).
- (3) Triac.
- (4) Field-effect transistor (FET).
- (5) Unijunction transistor (UJT).
- (6) Light-emitting diode (LED).
- (7) Photocell.

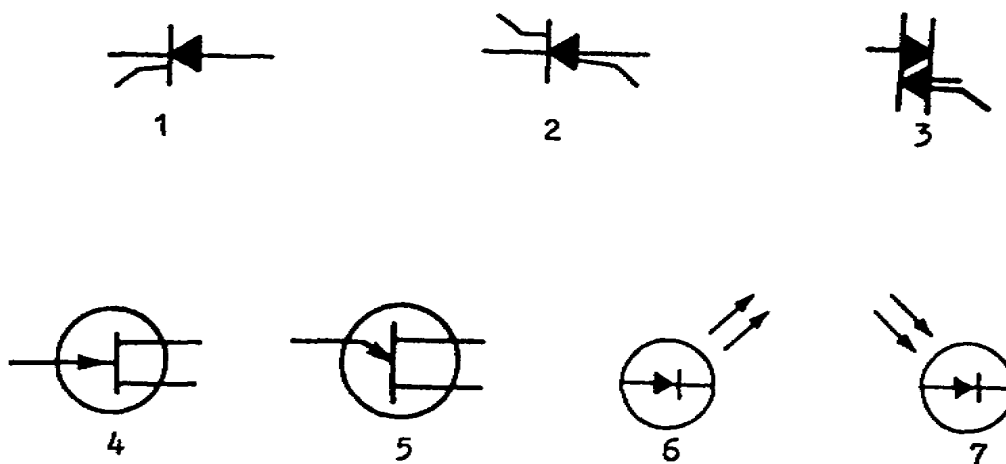

Figure 1-30. Special Purpose Solid-State Devices.

8. Digital Circuits. Many modern electronic systems rely heavily on the use of digital circuits. Digital circuits are essentially circuits within a circuit that perform a specialized function. Digital circuits make use of two distinct voltage levels, a high level and a low level, to convey information and to control functions within the circuit. These two voltage levels are known as the "logic" levels of the digital circuit. In order to understand and work with digital circuits, it is necessary to have an understanding of the binary numbering system and Boolean algebra. The details of the binary system and Boolean algebra are beyond the scope of this subcourse. For a review of these principles, see FM 11-72, Digital Computers.

The basic elements used in digital circuits are gates. Gates are special circuits that produce a high or a low output based on the high or low levels of two or more inputs. There are two primary types of digital gates, with several variations.

a. AND Gates. The AND gate is a digital circuit designed to produce a high level output when all input levels are high. If any of the input levels is low, the output of the gate will be low. AND gates are represented by the symbol shown in figure 1-31A.

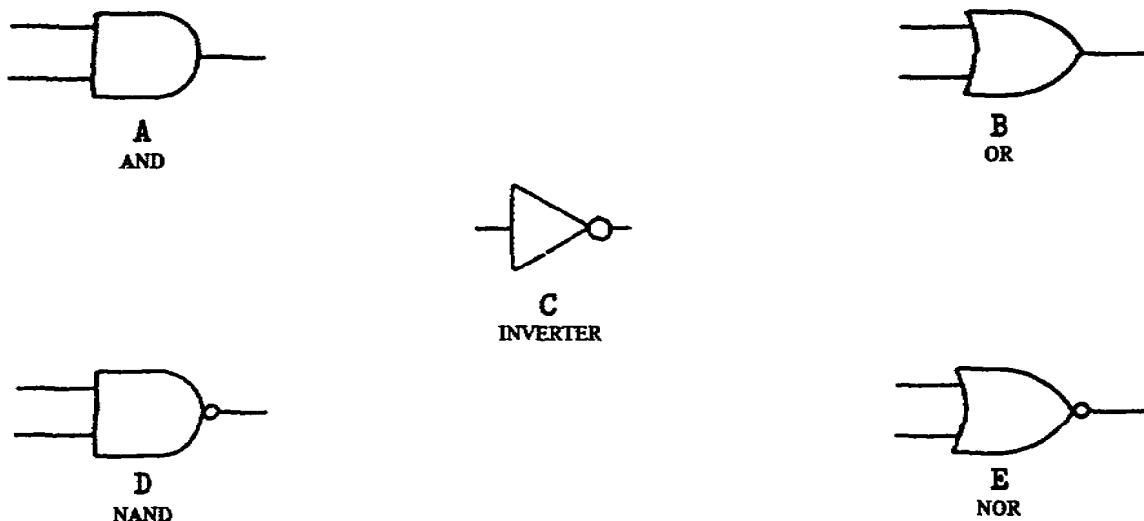

Figure 1-31. Logic Circuit Gates.

b. OR Gates. The OR gate is designed to produce a high level output when any one of the input levels is a high level. OR gates are represented by the symbol shown in figure 1-31B.

To provide variations to the two basic gates, inverters are used at either the input or the output of the gate. The inverter is used to change the logic level of the input or output from a high to a low, or from a low to a high. The symbol for a logic

inverter is shown in figure 1-31C. Inverters, when placed at the input or output of the basic gates, may provide a variety of combinations. When the inverter is used with the basic gate, only the small circle of the inverter symbol is used in the schematic diagram. Figure 1-31D shows an AND gate with an inverter at its output. The result is a NAND gate. Similarly, placing an inverter at the output of an OR gate will produce a NOR gate (figure 1-31E). Figure 1-32 shows the variations of two-variable AND gates and OR gates, and the resulting "truth table" for their output.

AND		OR		A	B	X
		H	H	H		
		H	L	L		
		L	H	L		
		L	L	L		
		H	H	L		
		H	L	L		
		L	H	L		
		L	L	H		
		H	H	H		
		H	L	H		
		L	H	H		
		L	L	H		

Two Variable, AND and OR Function

Figure 1-32. Two-Variable Truth Table.

9. Other Symbols. Many other symbols exist and may be found on schematic diagrams. It would be impractical to attempt to illustrate them all. However, the symbols discussed below are components that are likely to be found in Army fire control applications.

a. Grounds. The circuit return or completion is normally accomplished through the use of grounds. Grounds are usually of two types:

(1) Earth ground is a direct conducting connection to the earth or some structure. The symbol used to represent earth ground is shown in figure 1-33A.

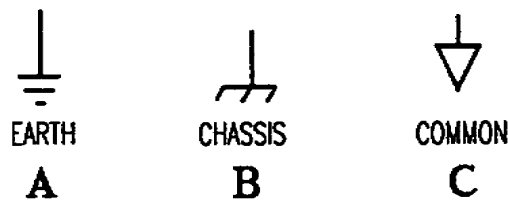

Figure 1-33. Ground Connections.

(2) Chassis ground is a conducting connection to the chassis or frame of the equipment or circuit. The chassis ground may not be at the same potential as the earth ground. The symbol for a chassis ground is shown in figure 1-33B.

A third symbol may be used to indicate a ground connection when all identically annotated return connections are at the same potential. The symbol for these common-ground connections is shown in figure 1-33C.

b. Antennas. Many electronic devices require the use of an antenna to receive input signals. The types of antennas used vary greatly, based on the function of the equipment. Figure 1-34 illustrates some of the common symbols used for antennas.

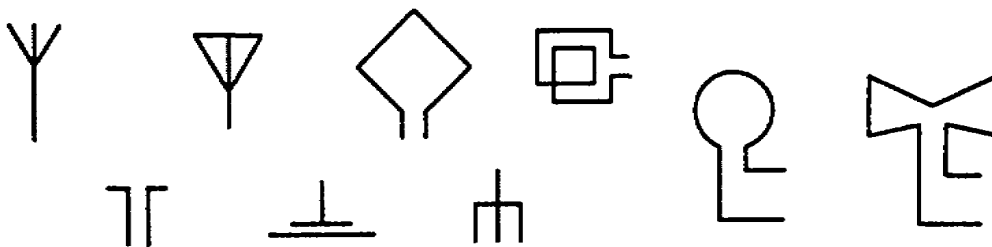

Figure 1-34. Antenna Symbols.

c. Microphones and Headphones. Some types of electronic devices permit audio inputs or outputs. Audio inputs are typically accomplished through the use of a microphone. The symbol for a microphone is shown in figure 1-35A. Audio outputs may be produced by the use of audio indicators such as discussed in paragraph 5e(1) or through the use of headphones. Headphones may be single or double. The symbols for single and double headphones are shown in figure 1-35B and 1-35C respectively.

d. Motors. Many electrical or electronic circuits are affected by drive motors. Motors are the electrical opposite of generators discussed in paragraph 4b. Motors convert electrical energy to mechanical energy. Like generators, motors may be either AC or DC. Figure 1-36 shows the symbols for motors.

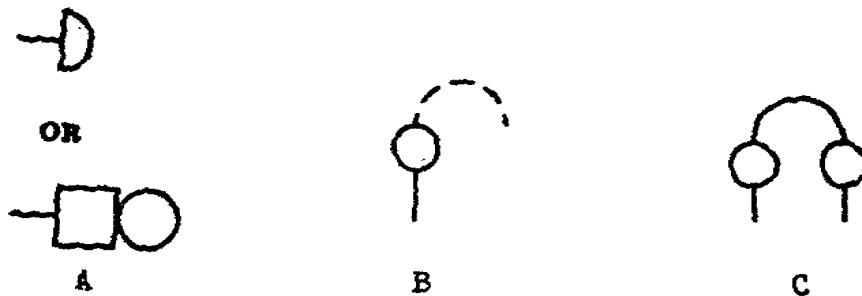

Figure 1-35. Microphones, Headsets.

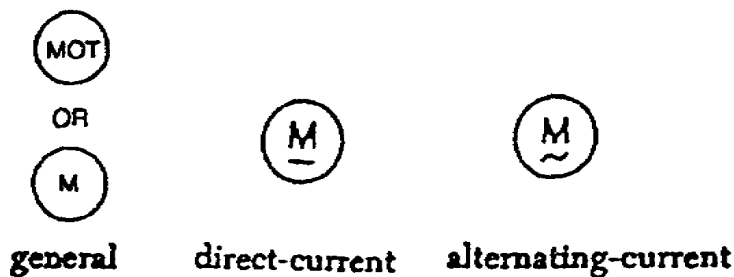

Figure 1-36. Motors.

PART B - COMPONENT CHARACTERISTICS AND FUNCTIONAL USE

Electrical and electronic circuits are made up of a variety of circuit components selected for their individual electrical properties. These components are arranged and connected within the circuit to produce the designed output. The schematic diagram is the road map of the circuit design. The symbols discussed in part A of this lesson to identify each component used to make up the circuit. Each component is placed into the circuit

to create the desired effect within the circuit. This part of the lesson will discuss some of the characteristics of the components and how their electrical properties are used in typical electrical and electronic circuits.

1. Basic Circuits. Electrical and electronic circuits may range from simple one-line circuits to extremely complex specialized systems. Probably the most simple practical circuit is that of the ordinary flashlight. Figure 1-37 illustrates the schematic diagram for a single cell battery powered flashlight.

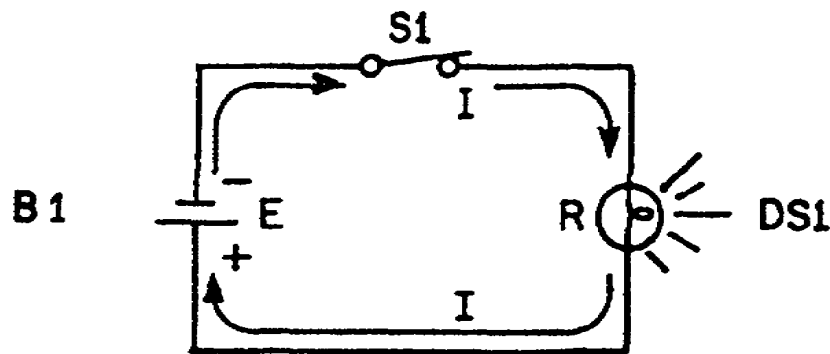
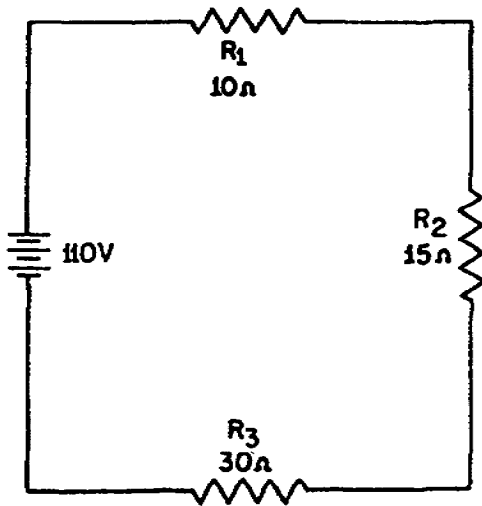

Figure 1-37. Flashlight Circuit.

The components are illustrated by their symbols. When the switch (S1) is closed, current flows through the conductor from the battery (B1) to the lamp (DS1) and back to the battery. Thus, the circuit is completed. The filament of the lamp acts as a resistor in this simple circuit. By resisting the current flow, the filament produces heat and the lamp lights. Resistors are used to control the amount of current in a circuit and to provide a voltage drop. Resistors may be connected in series or in parallel with other resistors or other electrical components to obtain the desired output. Figure 1-38 illustrates series and parallel connected resistors in a simple circuit.

Capacitors are components that have the ability to store electrical energy, block direct current, and permit the flow of alternating current. This unique ability to pass AC while blocking or isolating DC makes the capacitor a key component in filter networks. Inductors (or coils), on the other hand, offer considerable opposition to AC, but little to DC. Inductors are also used in filter circuits extensively. Through selecting the proper set of components, filtering circuits may be designed to produce the required output for the circuits they supply. Figure 1-39 illustrates the schematic of a simple filter circuit employing resistors, capacitors, and inductors.



SERIES CIRCUIT

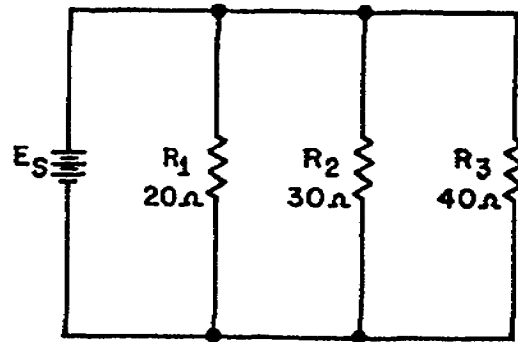

PARALLEL CIRCUIT

Figure 1-38. Series and Parallel Connected Resistors.

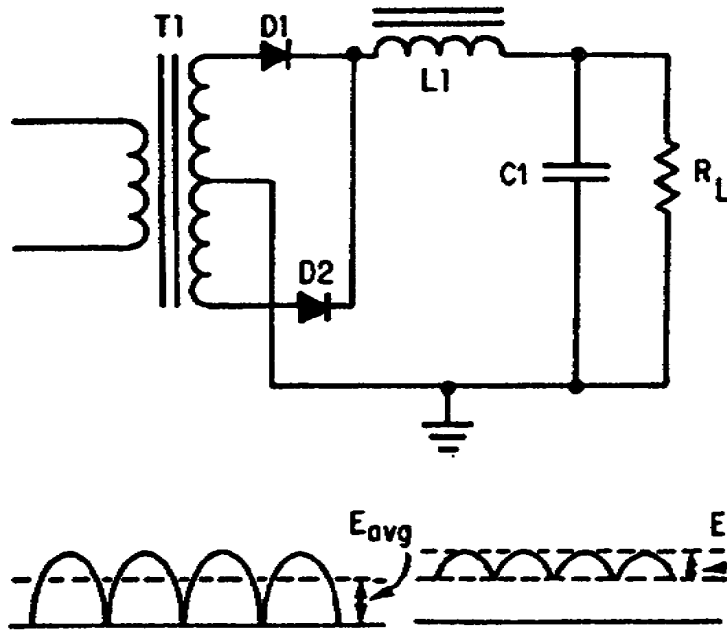

Figure 1-39. Filter Circuit.

Inductors are also elements of the transformer used in the circuit in figure 1-39. The primary of T_1 induces its AC voltage onto the secondary of T_1 . In this case the secondary of the transformer is center tapped to provide dual outputs in the secondary. Transformers may be designed to produce a variety of outputs relative to their input. Figure 1-40 shows a typical power transformer with outputs of 5, 6.3, 350, and 700 volts from a 110 volt input.

2. Rectifiers. The purpose of most power supply units is to convert some AC input to the desired DC output(s) in order to operate the circuits supplied. In figure 1-41 you can see that this conversion takes place in the element labeled as the rectifier. Rectification may be half-wave or full-wave. Figure 1-41A illustrates the schematic for a simple half-wave rectifier and its resultant waveform. Figure 1-41B shows a full-wave rectifier diagram and waveform.

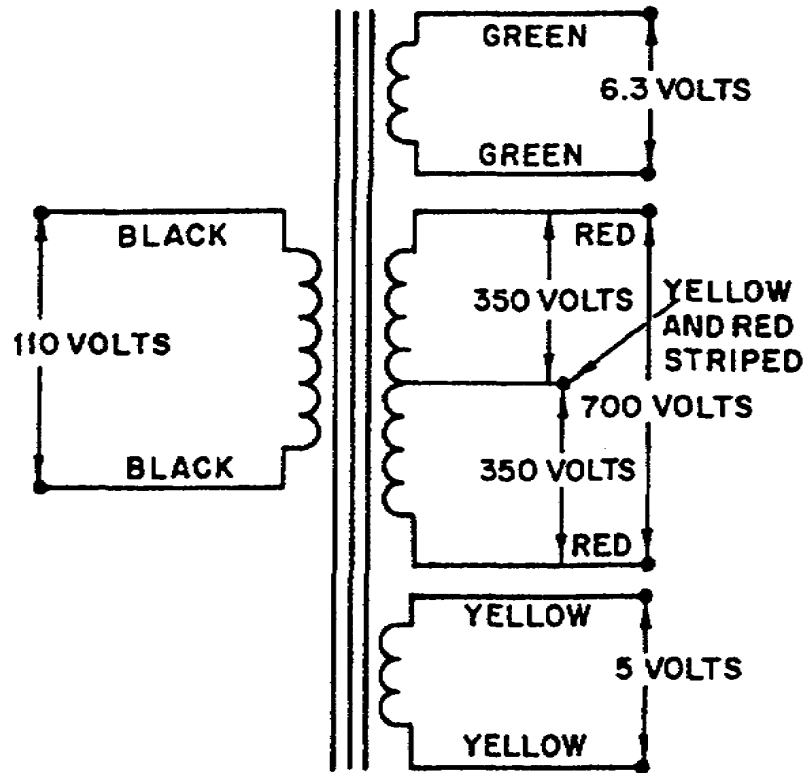

Figure 1-40. Power Transformer.

The component common to almost all types of rectifiers is the diode. The diode may be a vacuum tube diode or a solid-state diode. Since a diode has the property of passing current in only one direction, it is ideally suited for converting AC to DC. In half-wave rectification, only one direction of current flow is used. In full-wave rectification, the diodes are so connected as to make use of the AC current in both directions, thus resulting in the waveforms shown in figure 1-41. Solid-state diodes are used in almost all modern applications.

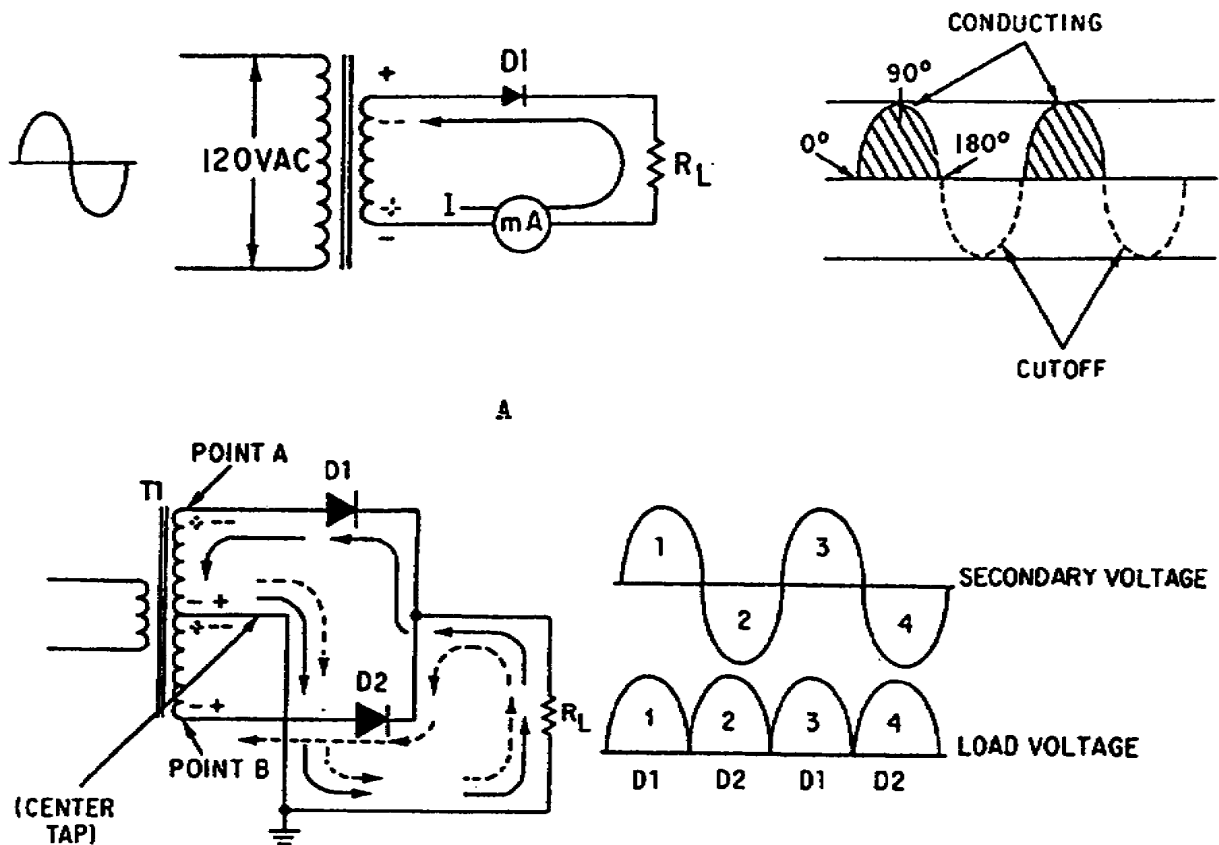

Figure 1-41. Rectifier Circuits.

3. Regulators. The fourth element of the power supply unit shown in figure 1-42 is the regulator. The purpose of the regulator is to provide an output voltage with little or no variation. Regulators sense changes in output and compensate for the changes. Regulators may also be designed to regulate the current flow. Voltage regulators may be classified as series or shunt (parallel), depending on their relative location in the circuit. Figures 1-42A and 1-42B show a shunt regulator and a series regulator respectively. In most modern practical applications, solid-state devices are used in regulator circuits. Figures 1-42C and 1-42D show shunt and series regulators employing solid-state components. Zener diodes are used extensively in regulator circuits. A zener diode blocks current until a specified voltage is applied. When the zener voltage is reached, the zener diode conducts, thus regulating the voltage developed across it.

4. Transistors. Probably no single event has had the impact on electronics as has the discovery of the transistor. Transistors have virtually replaced vacuum tubes in most modern electronic applications. Additionally, transistors have been designed to perform functions not previously attainable with vacuum tubes.

The most basic and the most common application of transistors is as an amplifier. Transistors may be configured to amplify voltage, current, or power as needed. Figure 1-43 shows a basic transistor amplifier circuit.

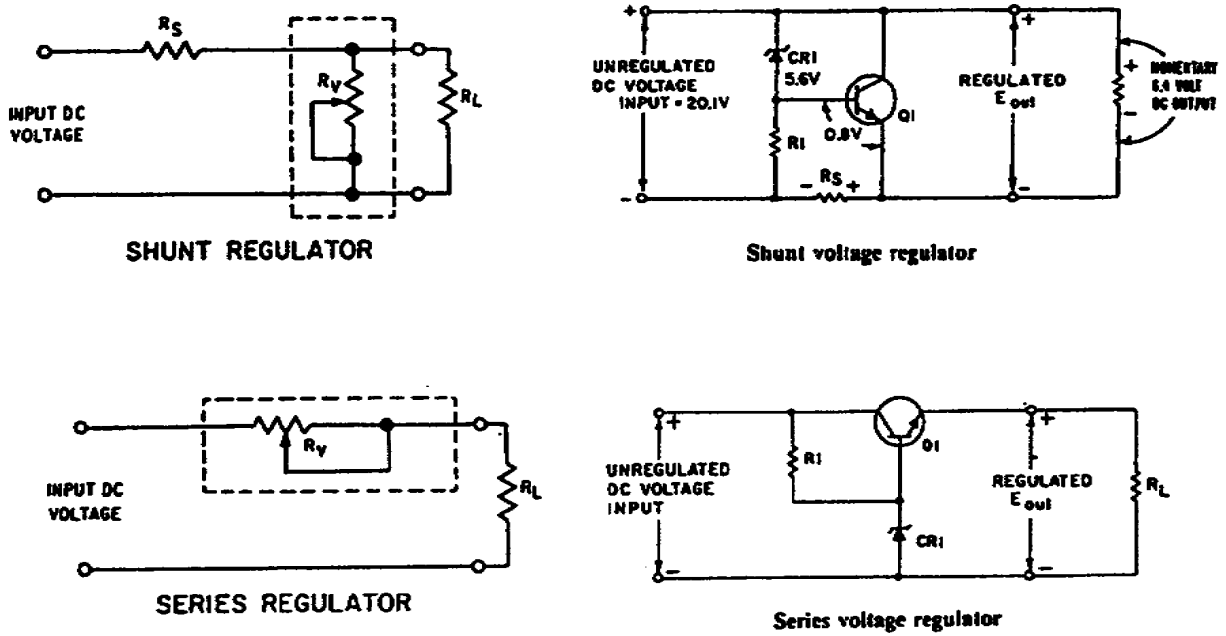

Figure 1-42. Regulator Circuits.

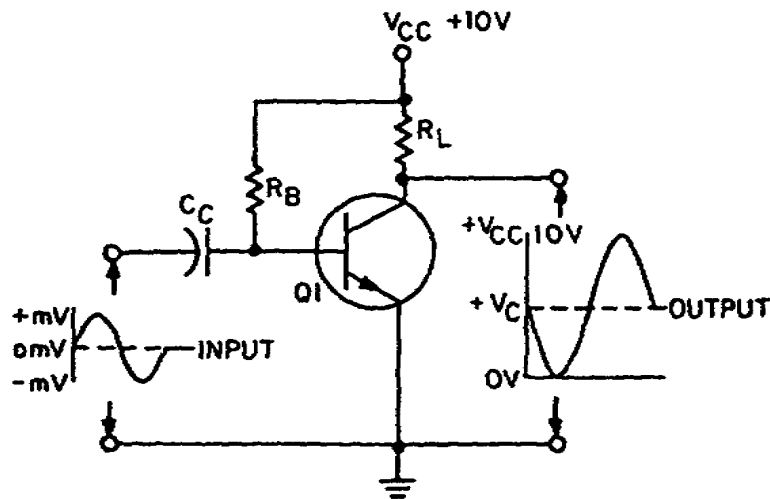

Figure 1-43. Transistor Amplifier.

Many types of special purpose transistors have been developed (and continue to be developed). The identification of transistors is often critical in the repair of electronic equipment. Transistors used in military applications can generally

be identified by a Joint Army-Navy (JAN) designation marked on the case of the transistor. Always replace transistors with ones that have the identical markings or a correct substitute. To ensure that you use an identical replacement or correct substitute, consult the equipment manual.

5. Digital Circuits. Digital circuits have been employed in an ever increasing number of applications. A digital circuit may operate as an electronic switch and is capable of making decisions or logic. Such a logic circuit represents a relationship between two or more variable inputs and a resultant output. Digital logic circuits form the basis for most types of computers. Digital circuits use gates, flip-flops, registers, and matrixes to perform a variety of functions. Digital circuits are often used in Army fire control instruments as counters, registers, displays, and other logic functions. Figure 1-44 illustrates a digital parallel counter.

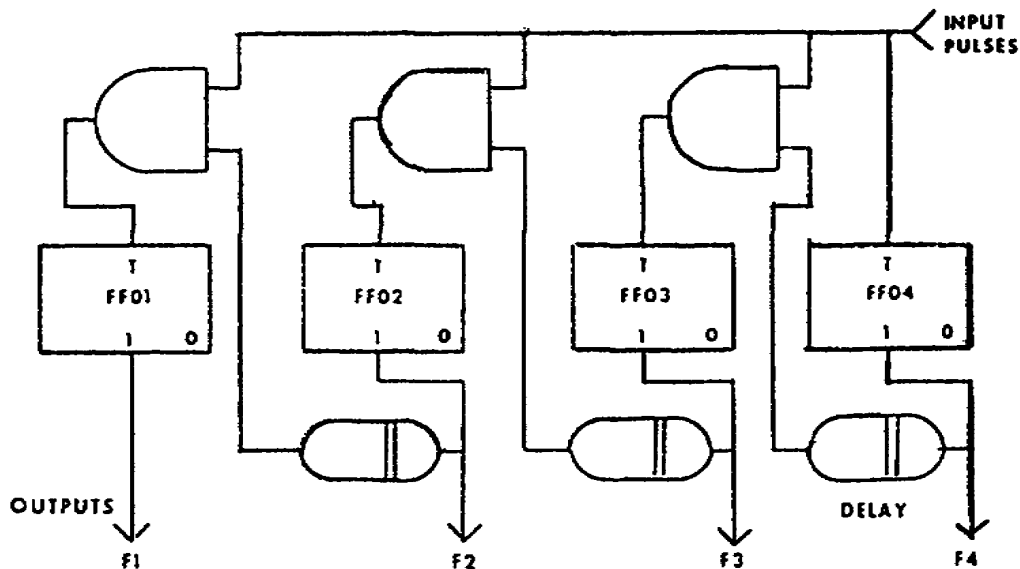

Figure 1-44. Parallel Binary Counter.

6. Complex Circuits. Most schematic diagrams you will find in equipment technical manuals will be much more complex than the simple circuits illustrated in this lesson thus far. Most circuits are a combination of the simpler circuits, arranged in a configuration to provide a series of electrical events, in order to produce some desired output or outputs. Figure 1-45 illustrates such a circuit. Input signals are introduced into the circuit through plug P1, processed through a series of electrical and electronic components, and output, again through plug P1.

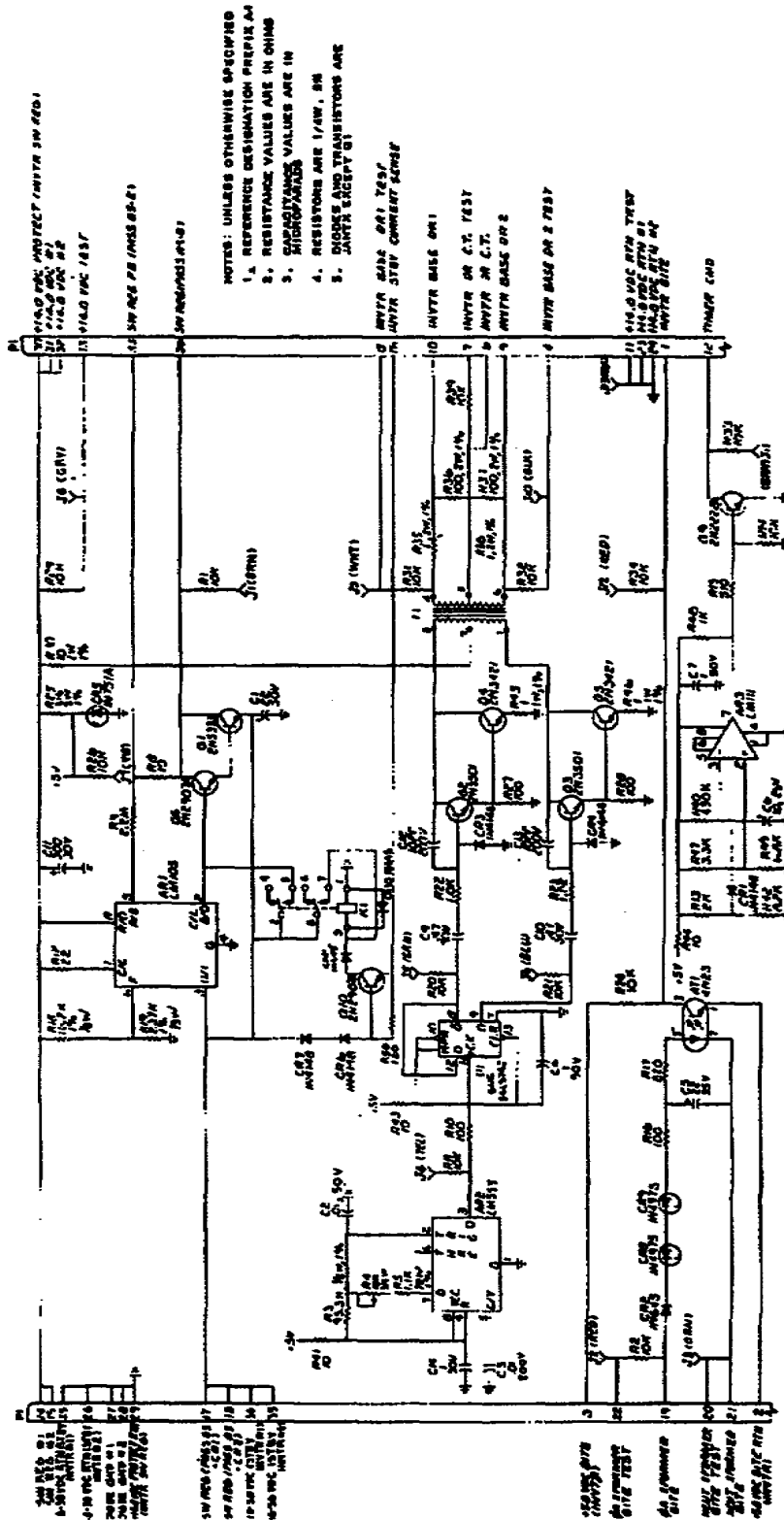

Figure 1-45. Complex Schematic Diagram.

At this point, you should be able to readily identify most of the symbols and annotations on the schematic diagram shown in figure 1-45.

PART C - WIRE TRACING

In addition to being able to "read" the schematic diagram of a circuit, it is often necessary to trace the source and/or the destination of a signal coming into the circuit or exiting from it. This is normally accomplished through a process of wire tracing. Depending on the design and construction of the equipment, wire tracing may be simple and confined to the internal parts of the equipment; or it may be complex and extend to distant external components.

Wire tracing procedures may vary greatly from one type of equipment to another. Probably the key to success in wire tracing is to have an understanding of the reference designators used to identify and locate equipment components. It is important to note that not all systems use the same methodology for assigning reference designators. Prior to performing wire tracing on actual equipment, refer to the appropriate technical manual.

NOTE: The following reference designator information is applicable to the tank thermal sight (TTS), AN/VSG-2. The wire tracing steps refer to the extracts from TM 9-5855-267-24 found in appendix c. The wire tracing sequences found in this lesson use table 3-2 of appendix C for solution. These procedures are for training only.

1. Reference Designators. Most equipment that requires the repairer to trace signals from one unit to another have some type of reference designator system. These reference designators are assigned to assist the repair technician in locating and identifying components as necessary for testing and repair.

The TTS, AN/VSG-2 uses the system described below to assign reference designators:

a. The first number in the reference designator represents the major unit in which the component is located. The major units of the TTS, AN/VSG-2 are:

- (1) Head assembly.
- (2) Gunner's display.
- (3) Commander's display.

- (4) Power converter.
- (5) Mount assembly.
- (6) Test set (TS-3681/VSG-2).

b. The second part of the reference designator is used to identify the location within the major unit, i.e., W1 for a wire harness, A2 for a unit subassembly, etc.

c. The third part of the designator locates the actual component, i.e., S1 for a switch, J2 for a jack, etc.

d. Following the reference designator, you will often find a pin or pin socket identifier for marking the exact circuit point for testing or troubleshooting.

e. The following examples are given to illustrate the use of reference designators in the TTS, AN/VSG-2.

(1) 2 W1 S1. This reference designator indicates S1 (mode switch) on the wiring harness W1 in the gunner's display.

- 2 - Gunner's display (unit 2).
- W1 - Wire harness W1.
- S1 - Switch 1 (mode switch).

(2) 4 A6 J1. This reference designator indicates connector jack J1 of the auxiliary regulator (subassembly A6) in the power converter.

- 4 - Power converter (unit 4).
- A6 - Auxiliary regulator.
- J1 - Connector J1.

(3) 2 W1 P4 (2 A3 J4). This reference designator indicates that the plug P4 of the wiring harness W1 in the gunner's display mates with jack J4 of the RPU assembly (A3) in the gunner's display.

- 2 - Gunner's display (unit 2).
- W1 - Wire harness W1.
- A3 - RPU assembly.
- P4 - Connector plug P4.
- J4 - Connector jack J4.

2. Voltage Measurements. One procedure that requires an understanding of reference designators in the TTS AN/VSG-2 is taking voltage measurements. Figure 1-46 is the voltage measurement table for the power converter. The probe connections for the measurements are indicated by the use of reference designators.

NOTE
 a. Always connect the LO (black) lead before you connect the HI (red) lead.
 b. Tolerances for voltages in table 3-1 are ± 10 percent unless otherwise noted.
 (See PO-12 for Location of Assemblies 4A1 through 4A2 and 4A9T1)

Item	Component checked	DMM probe connections		Voltage reading	
		LO (BLACK)	HI (RED)	ac (Tolerance $\pm 10\%$)	dc
	Inverter 4A1				
1	115 vac, 400 Hz	4A1J3	4A1J2	115	
2	+5.0 vdc	4A1J13	4A1J7		+5.0
3	+14.0 vdc	4A1J13	4A1J8		+14.0
	Controller 4A2				
4	-15.0 vdc	4A2J10	4A2J12		-15.0
5	+15.0 vdc	4A2J10	4A2J14		+15.0
6	18 to 30 vdc	4A2J10	4A2J15		+18 to +30
7	+5 vdc	4A2J10	4A2J16		+5.0
	Video rectifier and filter 4A3				
8		4A3J2	4A3J1	18.8	
9		4A3J5	4A3J4	17.5	
10		4A3J5	4A3J8	19.1	
11		4A3J7	4A3J11	15.6	
12		4A3J10	4A3J3		20.9
13		4A3J2	4A3J6		19.1
14		4A3J8	4A3J9	18.3	
15		4A3J11	4A3J10		-17.1
	Auxiliary rectifier and filter 4A4				
16		4A4J2	4A4J1	10.0	
17		4A4J4	4A4J5	10.0	
18		4A4J8	4A4J7	23.1	
19		4A6J11	4A4J10	23.0	
20		4A4J13	4A4J14	21.4	
21		4A6J2	4A4J3		7.4
22		4A6J4	4A4J6		-7.5
23		4A6J8	4A4J12		19.1
24		4A6J10	4A4J15		-19.6
25		4A2J10	4A4J9		18.9
	Video regulator 4A5				
26		4A5J2	4A5J1		+20.8
27		4A5J2	4A5J3		+10.74
28		4A5J5	4A5J6		+19.00
29		4A5J5	4A5J6		+9.93
30		4A5J8	4A5J7		+18.25
31		4A5J8	4A5J9		+10.12
32		4A5J11	4A5J10		-17.07
33		4A5J11	4A5J12		-8.05
	Auxiliary regulator 4A6				
34		4A6J2	4A6J1		+7.45
35		4A6J2	4A6J3		+5.02
36		4A6J4	4A6J5		-7.52
37		4A6J6	4A6J5		-4.93
38		4A6J8	4A6J7		+19.15
39		4A6J8	4A6J9		+14.7
40		4A6J10	4A6J11		-19.06
41		4A6J12	4A6J11		-14.6
	Transformer 4A9T1				
42		4A9T1-4	4A9T1-5	19.4	
43		4A9T1-6	4A9T1-7	17.9	
44		4A9T1-8	4A9T1-9	19.4	
45		4A9T1-10	4A9T1-11	16.4	
46		4A9T1-12	4A9T1-13	10.3	
47		4A9T1-14	4A9T1-15	10.3	
48		4A9T1-16	4A9T1-17	23.7	
49		4A9T1-18	4A9T1-19	22.2	
50		4A9T1-20	4A9T1-21	23.8	

Figure 1-46. Voltage Measurement Table.

3. Continuity Checks. Continuity checks can be made between various points in a circuit using a meter and wiring diagrams. However, continuity charts are provided for ease in performing the checks. These charts use reference designators as a basis for their format. Appendix C is such a continuity chart for the TTS, AN/VSG-2. It consists of table 3-2 and included figures from TM 9-5855-267-24.

NOTE: All continuity checks are made with a DMM set at 2K ohms.

In appendix C, the circuit points used to conduct continuity checks are found in the two left hand columns. These circuit points are identified by their reference designators. In this table, the reference designators are indicated in one of two ways:

a. Refer to page 3-5 of appendix C. At the top of the page, the statement is made, "prefix all test points 3W4." Only the remainder of the reference designator is indicated in the circuit point columns.

b. Refer to page 3-10 of appendix C. The entire reference designator is represented in the circuit point columns.

The center column of table 3-2 of appendix C (signal function or name) identifies the signal carried on the wire being checked. The remaining columns provide information pertaining to the conductor.

4. Signal Tracing. Many signals produced in one unit of the equipment are sent or applied to another unit of the equipment. Often it is necessary for the repairer to "trace" these signals from one unit to the other. This is accomplished by wire tracing. Table 3-2 and its accompanying figures may be used to trace various signals from unit to unit within the TTS, AN/VSG-2 and its test set. The following example will demonstrate signal tracing in the TTS, AN/VSG-2.

NOTE: All page numbers identified in the wire tracing sequences below refer to appendix C.

The following procedures will be used to trace the WFOV CMD from circuit point 2W1P4-20 to 1W1XA4-8:

a. The reference designator 2W1P4-20 indicates that this circuit point is located in the gunner's display. Therefore, you will locate the circuit point in the gunner's wire harness

chart (page 3-13). You must now locate the circuit point 2W1P4-20. It is found in the middle of page 3-14. You will find that the WFOV CMD travels from circuit point 2W1P4-20 to 2W1J1->D.

b. Since 2W1J1 is an external connection (see page 3-11), it is necessary to refer to the interface diagram (page 3-4). You will find that J1 of the gunner's display meets with the interface cable at 3W4P4.

c. To locate the connecting circuit point on the tank interface cable, you use the tank interface cable chart beginning on page 3-5. The WFOV CMD meets with 3W4P4 at 3W4P4->D (page 3-7). The WFOV CMD signal travels from 3W4P4->D to 3W4P3-Y.

d. Since 3W4P3 connects to the head assembly at head assembly J1, you will need to refer to the head assembly wire harness (page 3-27). You will find that the WFOV CMD meets 1W1J1 at the circuit point 1W1J1-Y (page 3-27). From 1W1J1-Y, the WFOV CMD signal travels to 1W1XA4-8, the terminal location of this signal.

e. The above wire tracing sequence is represented as indicated below:

- (1) 2W1P4-20.
- (2) 2W1J1->D.
- (3) 3W4P4->D.
- (4) 3W4P3-Y.
- (5) 1W1J1-Y.
- (6) 1W1XA4-8.

5. In order to ensure that you understand the method of wire tracing in the TTS, AN/VSG-2, trace the following signals as indicated. Fill in the missing circuit point designators.

a. Trace the CMDR CABLE BITE signal from 3W1P1-3 to 4W1XA6-24.

- (1) 3W1P1-3
- (2)
- (3)
- (4)
- (5)
- (6) 4W1XA6-24

b. Trace the STBY CMD from 4W1XA10-20 to the mode switch on the gunner's display.

- (1) 4W1XA10-20
- (2)
- (3)
- (4)
- (5)
- (6)

The solutions to these wire tracing sequences are found at the end of this lesson. If you are unsuccessful in tracing these two signals, reread paragraph 4 and attempt the wire tracing sequences again.

Remember, the procedures for assigning reference designators and for wire tracing vary with different equipment. Always refer to the current technical manual for the specific equipment you are working on.

6. Wire Tracing Sequence Solutions. The solutions to the wire tracing sequences in paragraph 5 were listed below with the page numbers from table 3-2 of appendix C. If you are successful, proceed to the Practice Exercise following this lesson.

a. Trace the CMDR CABLE BITE signal from 3W1P1-3 to 4W1XA6-24.

- (1) 3W1P1-3 (3-10)
- (2) 3W1J1-R (3-10)
- (3) 3W4P5-R (3-7)
- (4) 3W4P1-Z (3-7)
- (5) 4W1J2-Z (3-17)
- (6) 4W1XA6-24 (3-17)

b. Trace the STBY CMD from 4W1XA10-20 to the mode switch on the Gunner's Display.

- (1) 4W1XA10-20 (3-23)
- (2) 4W1J2->W (3-23)
- (3) 3W4P1->W (3-5)
- (4) 3W4P4-R (3-5)
- (5) 2W1J1-R (3-13)
- (6) 2W1S1-2 (3-13)

LESSON

PRACTICE EXERCISE

Read the following situation and use that information to answer the items in this Practice Exercise. Check your answers with the answers that follow.

Situation: You are the Fire Control maintenance NCO (MOS 45G20) at Headquarters, Headquarters Company, 3/78th Battalion (mechanized). You are conducting training for your unit technicians to prepare them for maintenance procedures required at the organizational level.

1. Transformers operate based upon which of the following principles?
 - A. Inductance.
 - B. Resistance.
 - C. Varactance.
 - D. Capacitance.

2. Typically, a power supply is employed to provide what function?
 - A. Convert a DC input to an AC output.
 - B. Convert an AC input to a DC output.
 - C. Increase a DC input to a higher DC output.
 - D. Increase an AC input to a higher AC output.

3. An audible alarm would be indicated on a schematic diagram by what letter identifier?
 - A. A.
 - B. S.
 - C. AA.
 - D. LS.

4. Which of the following vacuum tubes is still widely used today?
 - A. Beam power tubes.
 - B. Cathode-ray tubes.
 - C. Cold cathode tubes.
 - D. Diode rectifier tubes.

5. The most common use for transistors is?
- A. Filtration.
 - B. Regulation.
 - C. Amplification.
 - D. Rectification.
6. Digital circuits are referred to as "logic" circuits and rely on which of the following numbering systems?
- A. Octal.
 - B. Binary.
 - C. Decimal.
 - D. Alphanumeric.
7. The reference designator for 1W1J1-4 in the TTS AN/GVS-2 would indicate that the circuit is located in what major unit?
- A. Test set.
 - B. Head assembly.
 - C. Power converter.
 - D. Gunner's display.
8. In order to check the continuity for the GUNNERS FAIL LIGHT signal in the gunner's wire harness, you would place the test probes at 2W1J3-5 and?
- A. 2W1P3-5.
 - B. 2W1P3-6.
 - C. 2W1XA2-32.
 - D. 2W1XA2-36.

LESSON

PRACTICE EXERCISE ANSWER KEY AND FEEDBACK

Compare your answers to the following solutions. If you answered any item incorrectly, review the page(s) and paragraph(s) referenced until you understand the instruction.

<u>Item</u>	<u>Correct Answer and Feedback</u>
1.	<p>A. Inductance.</p> <p>Transformers are basically two inductors placed in close physical proximity. The electrical field of the primary is induced into the secondary, thus transferring the power. (page 8, para 4c)</p>
2.	<p>B. Convert an AC input to a DC output.</p> <p>Typically a power supply takes an AC input and converts it to a DC output through use of a transformer, rectifier, filter and regulator. (page 10, para 4d)</p>
3.	<p>D. LS.</p> <p>Audible indicators may be a horn, buzzer, speaker, etc. and are designated by "LS." (page 13, para 5e(1))</p>
4.	<p>B. Cathode-ray tube.</p> <p>Cathode-ray tubes are used to present a video display such as in a TV screen or radar display. This unique feature of the CRT cannot be duplicated by the use of transistors. Thus, they are still widely used today. (page 19, para 6)</p>
5.	<p>C. Amplification.</p> <p>The most basic and the most common use of transistors is to amplify voltage, current, or power. (page 27, para 4)</p>
6.	<p>B. Binary.</p> <p>Digital circuits use two distinct voltage levels, producing "1" and "0" logic levels. This results in a binary (two digits) numbering system. (page 19, para 8)</p>

Item Correct Answer and Feedback

7. B. Head assembly.

The first number of the reference designator used in the TTS AN/VSG-2 represents the major unit. The major unit represented by the number 1 is the head assembly. (page 30, para 1a(1))

8. C. 2W1XA2-32.

The other end of the connector designated to carry the GUNNERS FAIL LIGHT is found in the continuity check wiring table found in appendix C. (page 3-13)

CONTINUE TO THE NEXT PAGE.